

# Utopia Split Systems

**HITACHI**  
Inspire the Next



air



## Models

### Utopia ES

(7.1-14 kW)

### Utopia IVX

(7.1-30 kW)

### Utopia DC Inverter

(5-14 kW)

### Utopia Fixed Speed

(6.3-12.5 kW)

### Utopia Centrifugal

(12.5-25 kW)



A young man with dark hair, wearing a light blue polo shirt, is smiling and looking down at a smartphone he is holding in his hands. The background is a bright, out-of-focus indoor setting.

# Contents

Company Profile	4
Utopia Split Systems	6
Unique Innovations	8
Technical Features and Benefits	10
System Free Indoor Units	14
Utopia ES	28
Utopia IVX	30
Utopia DC Inverter	32
Utopia Fixed Speed	34
Utopia Centrifugal	36
Total Heat Exchanger	38
Control Systems	40
Optional Parts	44

Air conditioning from Hitachi can justifiably be described as the art of exploiting the latest ideas and developments in technology to create a range of innovative products which provide a more comfortable and more productive environment in which people can happily live and work. It is also an art executed with a responsible concern for protecting the environment. Ecological thinking begins at the very first stages of new product design and continues throughout production, installation procedures, equipment and operation.

Specifiers and users alike can always be assured that performance and costs are not the only parameters by which Hitachi products can be judged.

To achieve success with such objectives on a global scale requires not only enormous resources but also a commitment to the future. As one of the largest companies in the world, Hitachi is well positioned to undertake this commitment with confidence that comes from successfully responding to the changing needs of people for over 90 years.

In 1993 HITACHI invested in a new purpose built, state of the art factory (HAPE) in Barcelona, Spain. The site of the factory was carefully chosen to accommodate further building on its 40,000 square meter site. The creation of a European manufacturing facility and customer training centre helps reduce production costs, speed up delivery times and enables full support to be given to all customers.

Hitachi's advanced air conditioning products are specified all over the world, wherever there is a requirement for ultimate performance and cost effective, long term reliability. A wide range of units coupled with a choice of advanced control systems mean Hitachi can provide solutions to meet every possible air conditioning application or specification. Authorised distributors all over the world contribute their own specialised technical support and practical assistance to provide individual system designs, commissioning and after sales service.

Hitachi Authorised Distributors are committed to providing an unrivalled support from a combination of experienced engineers, local



Hitachi Air Conditioning Products Europe  
HAPE works, Spain



Hitachi Appliances, Inc.  
Shimizu works, Japan

## Company profile

In Japanese, Hitachi means sunrise – we are the forefront of research and development turning new ideas and innovations into new products. Of its \$80.9 billion sales worldwide in 2005, close to 4.3% was invested in research and development programs. This vast amount of money has given HITACHI the opportunity to conceive many 'world firsts' – examples of which include the technologically advanced and acclaimed scroll and semi-hermetic Screw compressors.

These have been incorporated in Hitachi's air conditioning systems and water chillers which have revolutionised air conditioning worldwide.

product and spare parts stock, supported in turn by on-going technical support from Hitachi.

From the initial product concept at Hitachi's research and development facility in Japan, product development is dedicated to providing the products the customer requires. Product design and development is continuous with priority being given to the use of ecologically friendly refrigerant.

To satisfy your cooling and heating requirements and to ensure the optimum indoor environment, consider Hitachi the first and last word in air conditioning.



Hitachi Air Conditioning Products (M)  
HAPM works, Malaysia



### Hitachi Air Conditioning Products Europe

(HAPE works, Spain) has acquired International Standard Quality Management System ISO9001 & ISO 14001 authorisation. HAPE performs thorough product quality control using various environmental tests. Hitachi Set Free Series Indoor units and panels are manufactured according to this ISO certification system.



### Hitachi Air Appliances Inc.

(Shimizu works, Japan) has acquired International Standard Quality Management System ISO9001 and ISO14001 authorisation. Shimizu works perform thorough product quality control using various environmental tests, severe heating testing for compressors, and many others. Hitachi Set Free Series Outdoor units are manufactured according to this ISO certification system.

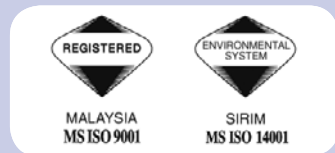

### Hitachi Air Conditioning Products (M) Sdn.Bhd

(HAPM works, Malaysia) has acquired International Standard Quality Management System ISO9001 and ISO14001 authorisation. HAPM perform thorough product quality control using various environmental tests. Hitachi Set Free Series RPK Indoor units are manufactured according to this ISO certification system.

# Quality control



# Utopia split systems

The Utopia range offers high performance and attractively priced systems for use in small buildings and commercial premises requiring intelligent environment facilities.

The range comes in four different types of models, the newly introduced Utopia ES, the Utopia IVX, the Utopia DC Inverter and the Utopia fixed speed giving you a wide variety of choice and allowing you to design an installation that best suits your requirements.

The Utopia IVX HRNME brings variable refrigerant flow and independent control to the Utopia range but at a fraction of the price

of standard VRF systems. Available in models from 3HP to 12HP the IVX is for slightly larger installations.

The Utopia DC-Inverter outdoor units range uses the proven combination of a Hitachi scroll compressor coupled with a DC inverter to provide increased efficiency with reduced noise.

Alternatively if you are looking for high quality and reliability at an even lower price than Hitachi suggests the Utopia Fixed Speed HN(V)E models which are available in a range from 2.5HP to 5 HP.

Also available in the fixed speed range is the Utopia Centrifugal which can be installed indoors in ducted installations.

All four models use the SYSTEM FREE range of indoor units enabling users to design their installations without having to worry about the type of indoor units needed. The Utopia Series is a system that is highly efficient, reliable and also has a wide range of choice allowing for maximum design flexibility and increased benefits for both installers and end users.

## Indoor Units

Capacity Range [HP]

	1.5	2.0	2.5	3.0	4.0	5.0	6.0	8.0	10.0
Mini 4-Way Cassette	●	●							
4-Way Cassette	●	●	●	●	●	●	●		
2-Way Cassette	●	●	●	●	●	●			
Mini Wall	●								
Wall	●	●	●	●	●				
Mini in the Ceiling	●								
In the Ceiling	●	●	●	●	●	●	●	●	●
Ceiling		●	●	●	●	●	●		
Floor-Standing	●	●	●						
Floor-Concealed	●	●	●						

## Utopia ES

Capacity Range [HP]

	3.0	4.0	5.0	6.0
Utopia ES	●	●	●	●

## Utopia DC Inverter IVX

Capacity Range [HP]

	3.0	4.0	5.0	6.0	8.0	10.0	12.0
HRNM Series	●	●	●	●	●	●	●

## Utopia DC Inverter

Capacity Range [HP]

	2.0	2.5	3.0	4.0	5.0	6.0
HVRN (1ph)	●	●	●	●	●	
HRN (3ph)				●	●	●

## Utopia Fixed Speed

Capacity Range [HP]

	2.5	3.0	4.0	5.0	10.0
HNVE (1ph)	●	●	●		
HNE (3ph)	●	●	●	●	
HNE (3ph, centrifugal)				●	●



Unique innovations

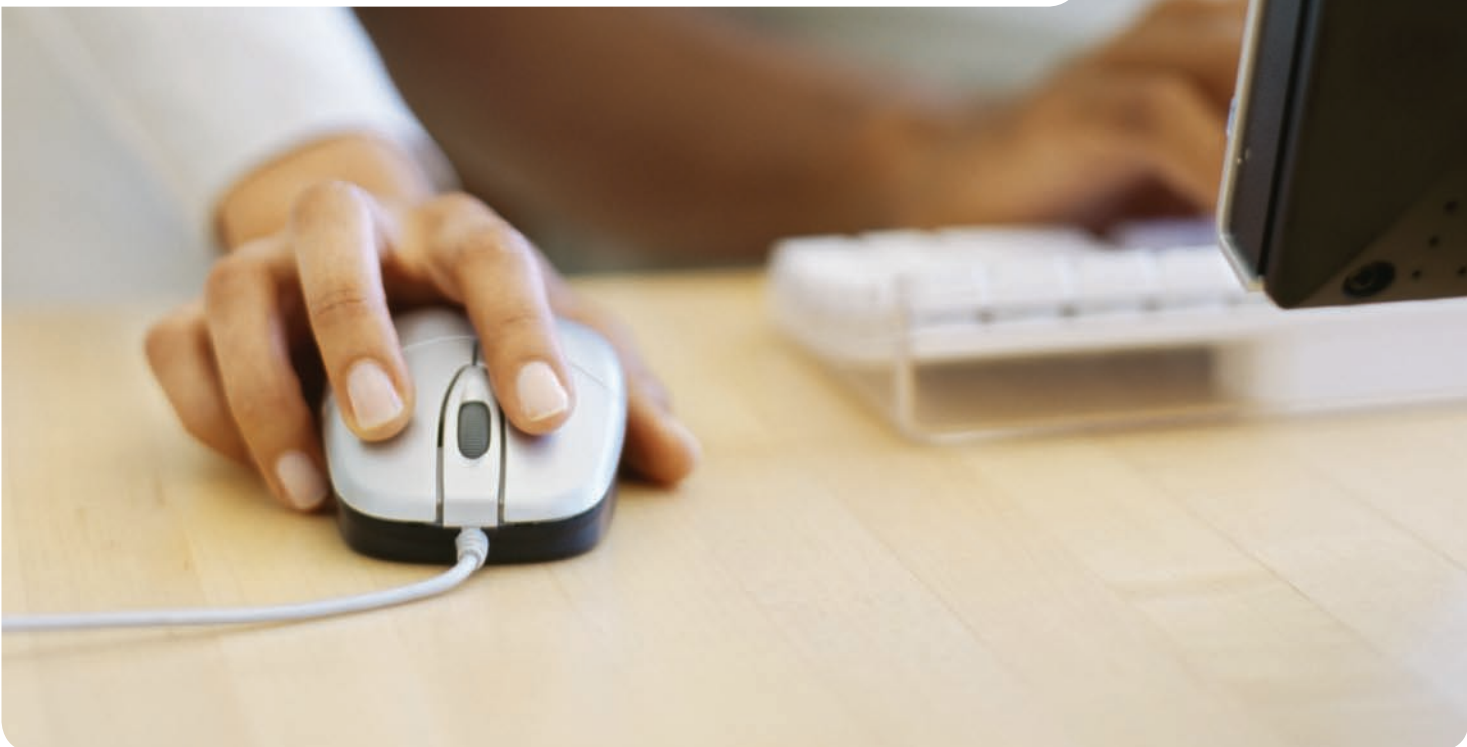



## Utopia IVX



### Greater Installation Flexibility

The IVX changes the way we think about twin, triple and quad split configurations and is the perfect choice for installations requiring individual unit control but have no need for the piping length capabilities available with more expensive VRF systems.

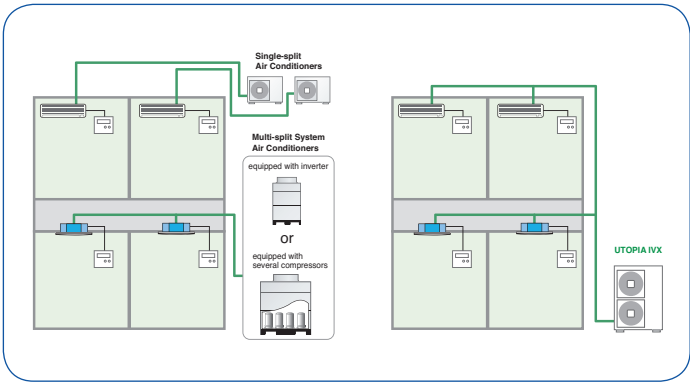

### More Efficient Control

By the use of individual control we can create a more comfortable environment for rooms that have unbalanced loads. This also leads to more economical operation as units not requiring operation will stop, reducing wasted energy.

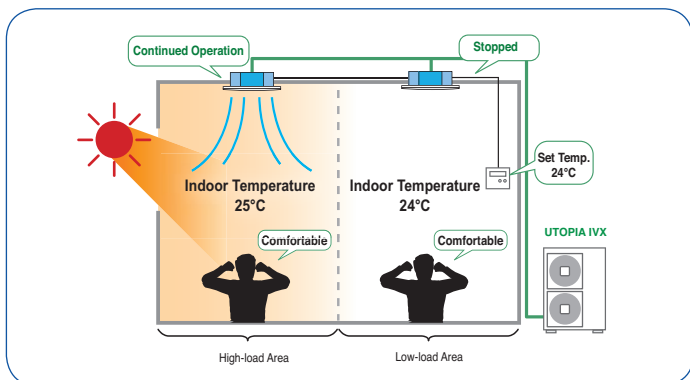

## Utopia Centrifugal



### Flexible Inlet Air and Outlet Air option

Four different configurations for Inlet and Outlet Air are available. Side panels and grilles could be changed in the field depending on each installation needs.

### Compatibility

Compatible with all Hitachi System Free indoor units.

### Utopia series control, H-Link connection

- H-LINK wiring system requires only two transmission wires connecting each indoor unit and outdoor unit for up to 64 refrigerant cycles, and connecting wires for all indoor unit and all outdoor units in series.
- Total wiring length is remarkably reduced.
- Only one connection is required for the wiring between the indoor unit and outdoor unit.
- Easy wiring connection to the central controllers.

### Fan Performance Curves

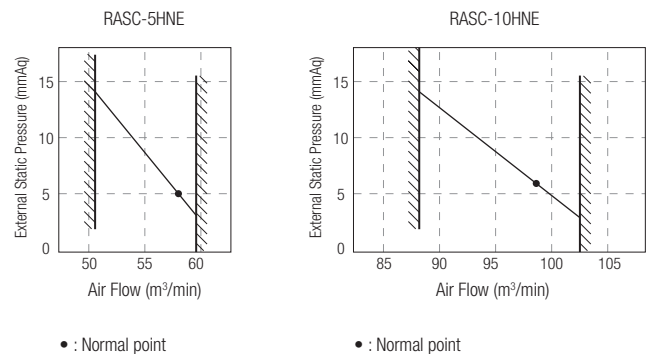

## Utopia Range EER

EER	
Utopia Fixed Speed (RAS-4HNE)	3.14
Utopia DC Inverter (RAS-4HVRNE)	3.85
Utopia IVX (RAS-4HRNME)	4.10
Utopia ES (RAS-5HVRNS(E))	3.22

Values shown for connection to RCI 4-way Cassette

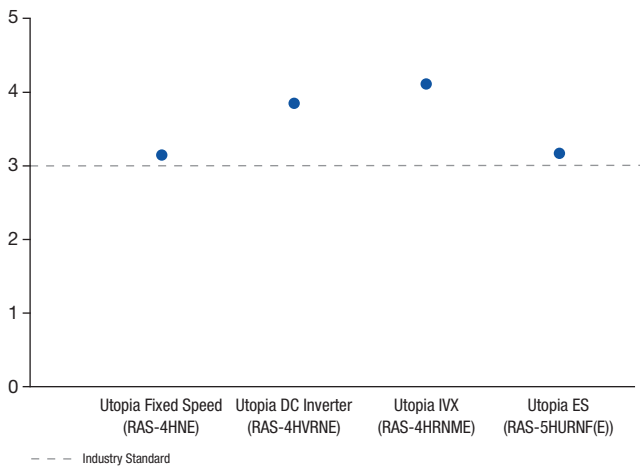

## Utopia Range COP

COP	
Utopia Fixed Speed (RAS-4HNE)	3.53
Utopia DC Inverter (RAS 4HVRNE)	4.39
Utopia IVX (RAS-8HRNME)	4.41
Utopia ES (RAS-5HVRNS(E))	3.48

Values shown for connection to RCI 4-way Cassette

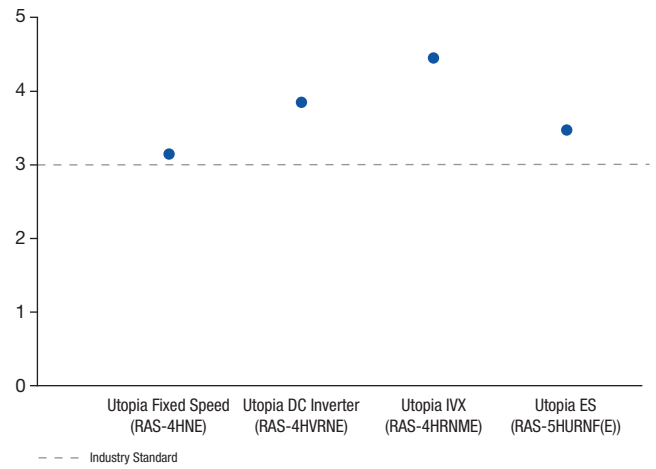

# Technical features & benefits



## H Link 11

H-Link requires only two transmission wires connecting each outdoor unit for up to 64 refrigerant cycles and connecting wires for all indoor units and outdoor units in the series.

The advantages of this system are:

- Flexible installation options
- No polarity requirements
- CS Net Connection via indoor or outdoor unit
- Can connect up to 160 indoor units
- Possible to have cable lengths of up to 1000m (5000m with H-link Relay)

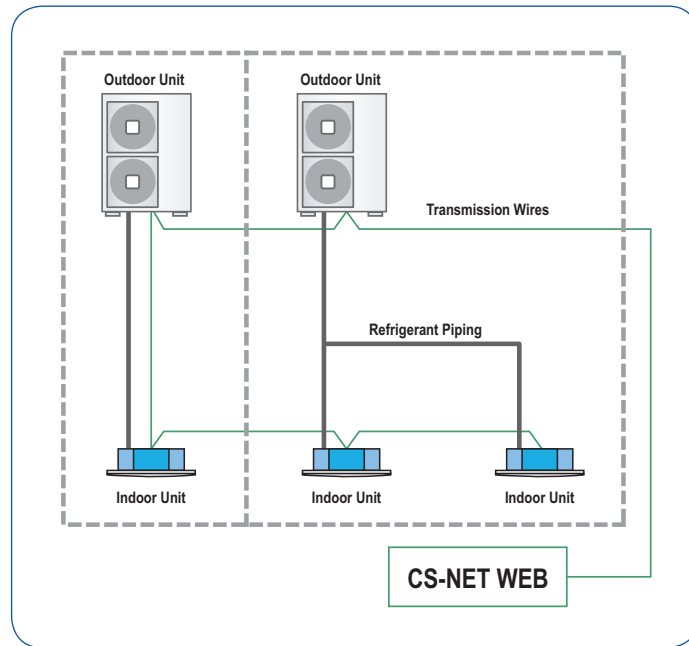

## Compact and Light

All outdoor units in the Utopia Range are now horizontal discharge type. The units have an extremely compact design allowing for easy installation and more effective use of plant space. This effective design and downsizing has led to a 40% reduction in the footprint of the Utopia IVX compared with previous models and a reduction in the amount of natural resources used.

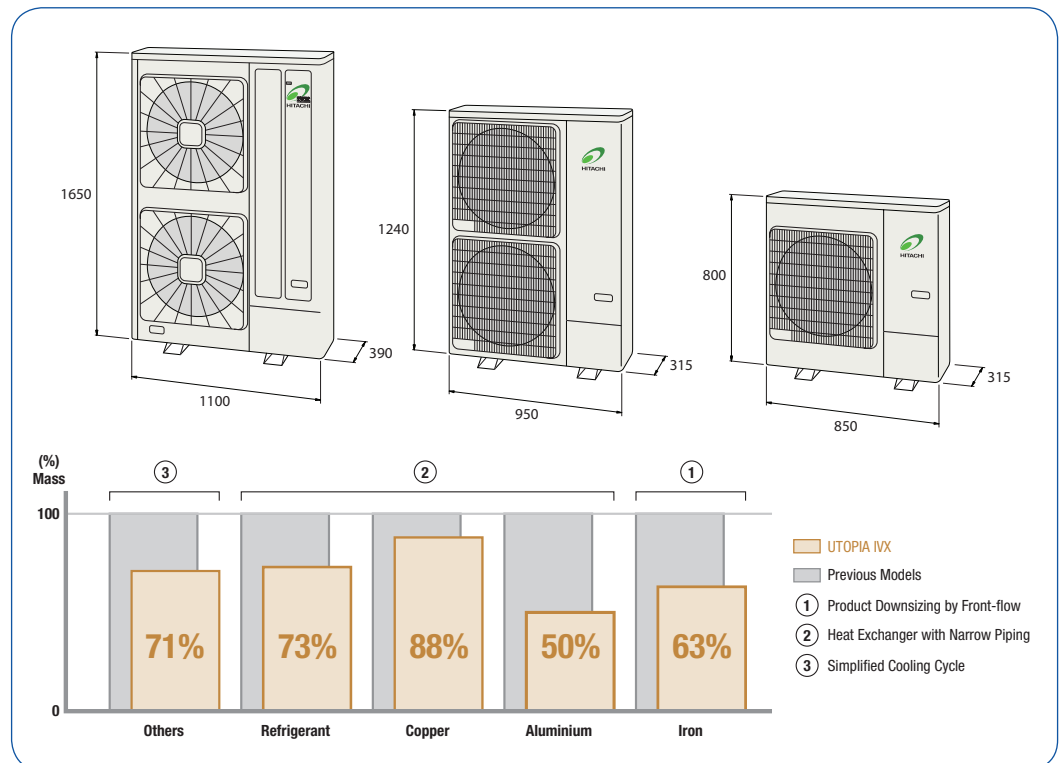



# Technical features & benefits

## DC Compressor

A DC compressor has improved performance around the 30 to 40 Hz range where compressor operation time is longest. Also to suppress electromagnetic noise and achieve low noise the compressor has a split rotor with displaced electrical poles.

Most of the operation time of the compressor is in the 30 to 40Hz range

- Rotor split and electric pole displaced to suppress electromagnetic noise.
- Characteristics at low speeds have also been improved making significant differences to the annual running costs.

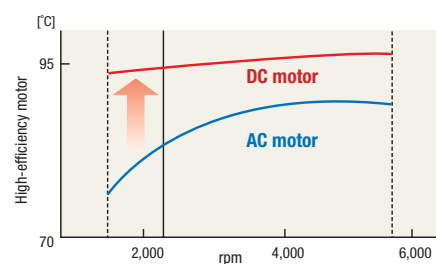
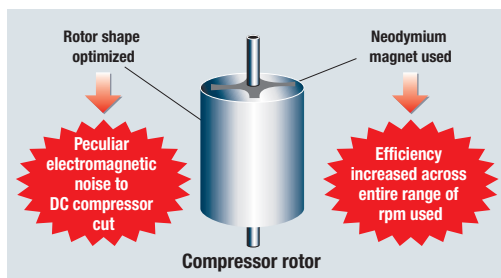

## Compressor Technology

Performance is greatly improved by the high efficiency high pressure inverter driven scroll compressor.



Features of the compressor:

- Optimised bearing
- Asymmetric scroll lap
- Oil return circuit
- Improved lubrication system
- High pressure shell
- Protection to allow for liquid return
- Reduced noise and vibration

### Improved lubrication system

The compressors use a pressure differential system for lubrication based on the difference between the intake and discharge pressure. Lubrication is very accurate and highly reliable throughout the operating range – even at low frequencies.

### High pressure shell

The high pressure shell acts as an oil separator reducing the amount of oil circulating in the refrigeration system giving better heat exchanger efficiency. This also prevents the oil entering the shell during the off cycle; this prevents oil dilution and oil foaming at start up.

In addition, the compressor intake gas does not circulate around the motor and therefore the heat of the motor is not added to the gas prior to compression. This is particularly important at low temperatures.

### Protection to allow for liquid return

When the compressor is not operating, the moving Scroll rests on the casing. When the compressor starts to run, the pressure in the chamber under the Scroll builds up and forces the Scroll up against the housing and seals the compression chamber. If liquid returns to the compressor, the resulting increase in pressure forces the Scroll downwards breaking the seal to allow the liquid to pass back into the compressor.

### Reduced noise and vibration

The compression points are evenly spread over compression stroke reducing sound and vibration levels. This is further enhanced by the minimal number of components used and the fact that the high pressure shell acts as a silencer.

## Quiet Operation – Super High-Stream Fan

Developments in fan technology have led to the production of the New Super Hi Stream Fan. The height of the fan has been reduced by 15% but advancements in the blade design and optimisation of the inlet and outlet angles have led to a 9% increase in efficiency while still maintaining low operating noise.

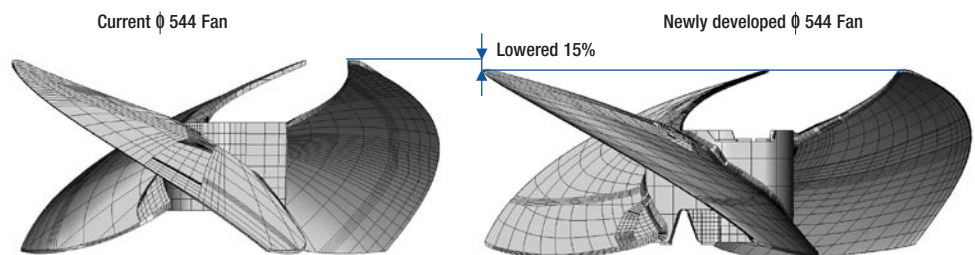
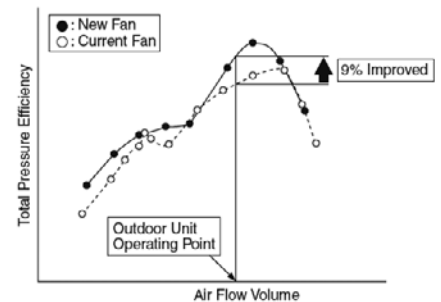
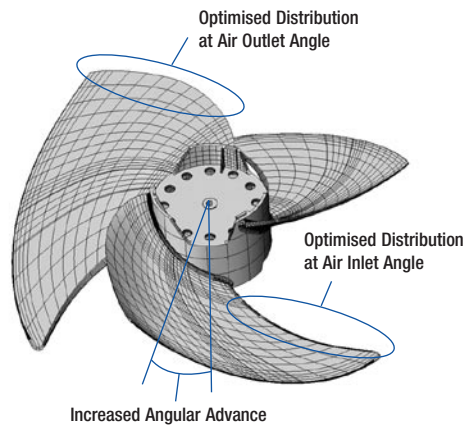

## RCIM-FSN Technical Description

- Quiet Operation
- Compact and Lightweight
- Easy Installation and Maintenance
- Improved Piping

The RCIM, Mini 4-way cassette indoor unit is extremely quiet, compact and has a range of features that benefit installation. Such as an adjustable mounting height, it is compact and lightweight and also it has a uniform panel size and uniform mounting positions allowing for easier piping connections.

### Quiet operation

The following table lists air flow rates for RCIM.

Model	Air Flow Rates and Noise levels dB(A)		
	Hi	Me	Lo
RCIM-1.5FSN	38	35	33
RCIM-2.0FSN	42	39	37

### DC Motor with Reduced Input and Noise

The DC fan motor greatly improves efficiency and reduces electromagnetic noise compared to conventional products that use AC motors. Air blasts are also reduced by controlling the rotation speed of the fan. In addition, the motor input is reduced by employing a ferrite magnetic surface-mounted rotor, centralized winding system and split core system. The motor efficiency is improved in all aspects, and is 50% smaller and lighter than conventional machines.

### Easy Installation and Maintenance

The units are just 295mm in height and weight is 17Kg, so they can be easily installed in the reduced space of a false ceiling. Also the panel sizes are standardised to a 700mm square to facilitate the installation in a standard grid ceiling (European standard module is 600mm).

The pitch size of the suspending bolts is 530mm, positioned at each corner of the square body. Thus, the orientation of the body can be changed easily to match the pipe connections without changing the bolt positions.

The electrical enclosure is located inside the grill which enables easier access to the electrical components without having to open the false ceiling. There is a pocket at each of the four panel corners so that the body height can be easily adjusted without removing the panel.

### Better Piping

A condensate pump lift of up to 600mm from the ceiling surface is achieved by employing a drain-up mechanism which is automatically activated by the water level when the draining process is required.

### Adaptable for High Ceiling Installations

Speed Setting	Ceiling Height (m)	
	RCIM-1.5FSN	RCIM-2.0FSN
Standard	Below 2.5m	Below 2.7m
Speed-up (1)	2.5 to 2.9	2.7 to 3.1
Speed-up (2)	2.9 to 3.9	3.1 to 3.5

Heights shown in metres

By incorporating the use of speed-up taps on the motor this model can be adapted for high ceiling (3.5m high) installations. This feature provides comfortable air conditioning in suburban stores and showrooms.



# Mini 4-way cassette

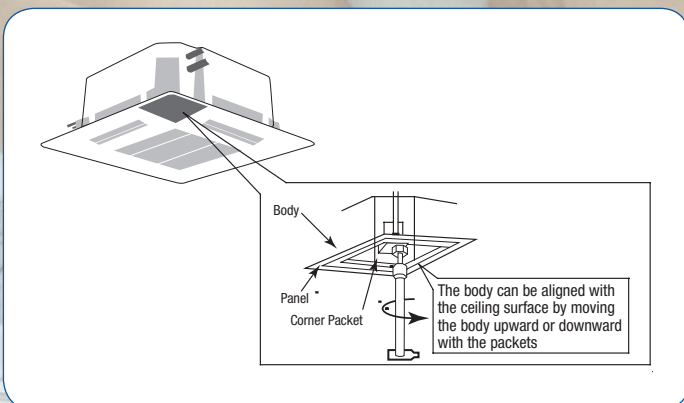

## General Data

Model		RCIM-1.5FSN	RCIM-2.0FSN
<b>Nominal Cooling Capacity</b>	kW	3.60	5.0
<b>Nominal Heating Capacity</b>	kW	4.00	6.30
<b>Air Flow Rate</b> (hi/me/lo)	m <sup>3</sup> /min	15/13.5/12	16/14/12
<b>Fan Motor</b>	W	52	52
<b>Sound Pressure Level</b> (Overall Scale) (hi/me/lo)	dB(A)	38/35/33	42/39/37
<b>Outer Dimensions</b>			
Height	mm	295	295
Width	mm	570	570
Depth	mm	570	570
<b>Net Weight</b>	kg	17	17
<b>Refrigerant</b>		R410 A ( Nitrogen Charged in Factory for Corrosion-resistance)	
<b>Connections</b>		Flare-nut Connection (with flare-nuts)	
<b>Refrigerant-Piping</b>			
Liquid Line	mm(in)	ø 6.35 (1/4)	ø 6.35 (1/4)
Gas Line	mm(in)	ø 12.7 (1/2)	ø 15.88 (5/8)
Condensate Drain	mm	ø 32 OD	ø 32 OD
<b>Packing Measurements</b>	m <sup>3</sup>	0.13	0.13
<b>Adaptable Air Panel</b>	-	P-N23WAM	
<b>Colour</b> (Munsell Code)	-	Spring white (4.1Y8.5 / 0.7)	
<b>Outer Dimensions</b>			
Height	mm	35	35
Width	mm	700	700
Depth	mm	700	700
<b>Net Weight</b>	kg	3.5	3.5
<b>Packing Measurements</b>	m <sup>3</sup>	0.07	0.07
<b>Remote Control Switch</b>	-	PC-P2HTE or PC-LH3A	

### NOTES:

OD: Outer Diameter

1. The nominal cooling and heating capacity is the combined capacity of the HITACHI standard split system, and are based on the JISB 8616.

#### Cooling Operation Conditions

Indoor Air Inlet Temperature: 27.0 °C DB  
19.0 °C WB  
Outdoor Air Inlet Temperature: 35.0 °C DB

#### Heating Operation Conditions

Indoor Air Inlet Temperature: 20.0 °C DB  
Outdoor Air Inlet Temperature: 7.0 °C DB  
6.0 °C WB

#### Piping Length: 7.5 meters

DB: Dry Bulb; WB: Wet Bulb

2. The Sound Pressure Level is based on the following conditions:

– 1.5 meters Beneath the Unit.

– Voltage of the power source for the indoor fan motor is 230V.

The above data was measured in an anechoic chamber so that reflected sound should be taken into consideration when installing the unit.

## RCI-FSN2E Technical Description

- Quiet Operation
- Compact and Lightweight
- Easy Installation and Maintenance
- Slim Air Panel
- Improved Piping
- Drain Pump as Standard

The RCI, 4-way cassette indoor unit is extremely quiet, compact and has a range of features that benefit installation. Such as an adjustable mounting height, it is compact and lightweight and also it has a uniform panel size and uniform mounting positions allowing for easier piping connections.

### Quiet operation

By employing a super-high-stream turbo fan (three-dimensional twisted wing), the wind flow efficiency has been improved by 20%, reducing noise of some units down to 28dB(A).

### DC Motor with Reduced Input and Noise

The DC fan motor greatly improves efficiency and reduces electromagnetic noise compared to conventional products that use AC motors. In addition, the motor input is reduced by employing a ferrite magnetic surface-mounted rotor, centralized winding system and split core system. The motor efficiency is improved in all aspects, and is 50% smaller and lighter than conventional machines.

### Easy Installation and Maintenance

The required opening in a ceiling has been reduced to between 860-910mm. This along with a maximum height of just 298mm and weight as low as 23Kg means they can be easily installed in the reduced space of a false ceiling. Also the panel sizes have been standardised to a 900mm square to facilitate the simple interchange of other models with different capabilities.

The pitch size of the suspending bolts is 760mm, positioned at each corner of the square body. Thus, the orientation of the body can be changed easily to match the pipe connections without changing the bolt positions.

There is a pocket at each of the four panel corners so that the body height can be easily adjusted without removing the panel.

### Better Piping

A condensate pump lift of up to 600mm from the ceiling surface is achieved by employing a drain-up mechanism which is automatically activated by the water level when the draining process is required.

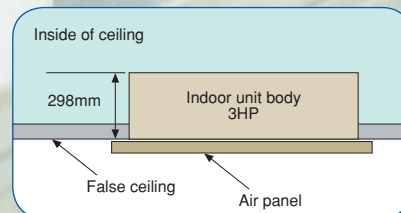

### Adaptable for High Ceiling Installations

Speed Setting	1.5/2.0/2.5/3.0 HP			4.0/5.0/6.0 HP		
	4-way	3-way	2-way	4-way	3-way	2-way
Standard	2.7	3.0	3.3	3.2	3.6	4.0
Speed-up (1)	3.0	3.3	-	3.6	4.0	4.2
Speed-up (2)	-	3.6	-	4.2	4.3	-

Heights shown in metres

By incorporating the use of speed-up taps on the motor this model can be adapted for high ceiling (4.2m high) installations. This feature provides comfortable air conditioning in suburban stores and showrooms.

# 4-way cassette

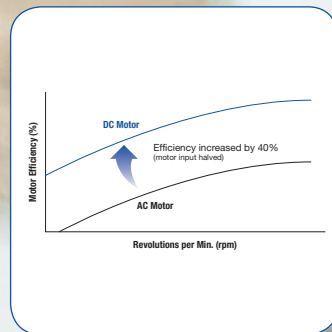



## General Data

Model	Units	RCI-1.5 FSN2E	RCI-2.0 FSN2E	RCI-2.5 FSN2E	RCI-3.0 FSN2E	RCI-4.0 FSN2E	RCI-5.0 FSN2E	RCI-6.0 FSN2E
<b>Nominal Cooling Capacity</b>	kW	3.60	5.00	6.30	7.10	10.00	12.50	14.00
<b>Nominal Heating Capacity</b>	kW	4.00	5.60	7.00	8.00	11.20	14.00	16.00
<b>Air Flow Rate</b> (hi/me/lo)	m <sup>3</sup> /min	15/14/12	16/14/12	20/17/15	26/23/20	32/28/24	34/29/25	37/32/27
<b>Fan Motor</b>	W	56	56	56	56	108	108	108
<b>Sound Pressure Level</b> (Overall A Scale) (Hi/Me/Lo)	dB(A)	32/30/28	32/30/28	32/30/28	34/32/30	38/35/33	39/37/35	42/40/36
<b>Outer Dimensions</b>								
Height	mm	248	248	248	298	298	298	298
Width	mm	840	840	840	840	840	840	840
Depth	mm	840	840	840	840	840	840	840
<b>Net Weight</b>	kg	23	24	24	26	29	29	29
<b>Refrigerant</b>	R410A (Nitrogen Charged in Factory for Corrosion-Resistance)							
<b>Connections</b>	Connection with Flare-Nuts							
<b>Refrigerant-Piping</b>								
Liquid Line	mm(in.)	ø 6.35 (1/4)	ø 6.35 (1/4)	ø 9.53 (3/8)	ø 9.53 (3/8)	ø 9.53 (3/8)	ø 9.53 (3/8)	ø 9.53 (3/8)
Gas Line	mm(in.)	ø 12.7 (1/2)	ø 15.88 (5/8)	ø 15.88 (5/8)	ø 15.88 (5/8)	ø 15.88 (5/8)	ø 15.88 (5/8)	ø 15.88 (5/8)
Condensate Drain	mm	ø 32 OD	ø 32 OD	ø 32 OD	ø 32 OD	ø 32 OD	ø 32 OD	ø 32 OD
<b>Packing Measurements</b>	m <sup>3</sup>	0.22	0.22	0.22	0.26	0.26	0.26	0.26
<b>Adaptable Air Panel Model</b>	-	P-N23WA						
<b>Colour</b> (Munsell Code)	-	Spring White (4.1Y8.5 / 0.7)						
<b>Outer Dimensions</b>								
Height	mm	37	37	37	37	37	37	37
Width	mm	950	950	950	950	950	950	950
Depth	mm	950	950	950	950	950	950	950
<b>Net Weight</b>	kg	6	6	6	6	6	6	6
<b>Packing Measurements</b>	m <sup>3</sup>	0.08	0.08	0.08	0.08	0.08	0.08	0.08
<b>Remote Control Switch</b>	-	PC-ART/PC-P2HTE						

### NOTES:

OD: Outer Diameter

- The nominal cooling and heating capacity is the combined capacity of the HITACHI standard split system, and are based on the ISO5151.

#### Cooling Operation Conditions

Indoor Air Inlet Temperature: 27.0 °C DB  
19.0 °C WB  
Outdoor Air Inlet Temperature: 35.0 °C DB

#### Heating Operation Conditions

Indoor Air Inlet Temperature: 20.0 °C DB  
Outdoor Air Inlet Temperature: 7.0 °C DB  
6.0 °C WB

Piping Length: 7.5 meters

Piping Lift: 0 meters

DB: Dry Bulb; WB: Wet Bulb

- The Sound Pressure Level is based on the following conditions:

- 1.5 meters beneath the Unit.

- Voltage of the power source for the indoor fan motor is 230V.

The above data was measured in an anechoic chamber so that reflected sound should be taken into consideration when installing the unit.

- Panel P-N23WA is equipped with an automatic swing louver system.

## RCD-FSN Technical Description

- Quiet Operation
- Slim line design
- New Air Panel, perfect fit for any ceiling

The RCD 2 way cassette produces very little noise, it has a new air panel resulting in a very low profile design.

### Quiet operation

By employing a super-high-stream turbo fan (three-dimensional twisted wing with large bore and high efficiency), the wind flow efficiency has been improved by 20% resulting in a noise reduction down to an exceptionally low 30dB (A). It is ideal wherever quiet operation is important.

### An Air panel perfect for any ceiling

This unit virtually merges with the ceiling; it only protrudes 30mm and provides space for customised panelling allowing the unit to blend perfectly into any ceiling.

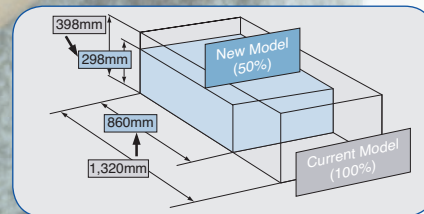

## 2-way cassette

### Low profile design

The compact turbo fan simplifies the structure and reduces the height of the unit to 298mm. The unit's low profile design allows easy installation in the most confined spaces inside a ceiling.

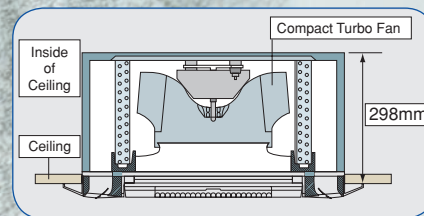

### Adaptable for High Ceiling Installations

By incorporating the use of speed-up taps on the motor this model can be adapted for high ceiling installations. This feature provides comfortable air conditioning in suburban stores and showrooms.

Speed Setting	1.5~2.5HP	3.0/4.0HP	5HP
Standard	2.4	2.7	2.9
Speed-up (1)	2.7	3.0	3.2
Speed-up (2)	2.9	3.2	3.4



## General Data

	Model	RCD-1.5FSN	RCD-2.0FSN	RCD-2.5FSN	RCD-3.0FSN	RCD-4.0FSN	RCD-5.0FSN
<b>Nominal Cooling Capacity</b>	kW	3.60	5.00	6.30	7.10	10.00	12.50
<b>Nominal Heating Capacity</b>	kW	4.00	5.60	7.00	8.00	11.20	14.00
<b>Air Flow Rate</b> (hi/me/lo)	m <sup>3</sup> /min	12/10/8.5	15/13/11	19/16/14	22/19/16	28/24/21	34/29/25
<b>Fan Motor</b>	W	35	35	55	55	35x2	35x2
<b>Sound Pressure Level</b> (Overall Scale) (hi/me/lo)	dB(A)	35/32/30	35/32/30	38/34/31	40/36/33	40/36/33	43/40/36
<b>Outer Dimensions</b>							
Height	mm	298	298	298	298	298	298
Width	mm	860	860	860	860	1420	1420
Depth	mm	620	620	620	620	620	620
<b>Net Weight</b>	kg	27	27	30	30	48	48
<b>Refrigerant</b>	R410A (Nitrogen Charged in Factory for Corrosion-resistance)						
<b>Connections</b>	Flare-nut Connection (with flare-nuts)						
<b>Refrigerant-Piping</b>							
Liquid Line	mm(in)	ø 6.35 (1/4)	ø 6.35 (1/4)	ø 9.53 (3/8)	ø 9.53 (3/8)	ø 9.53 (3/8)	ø 9.53 (3/8)
Gas Line	mm(in)	ø 12.7 (1/2)	ø 15.88 (5/8)	ø 15.88 (5/8)	ø 15.88 (5/8)	ø 15.88 (5/8)	ø 15.88 (5/8)
Condensate Drain	mm	ø 32 OD	ø 32 OD	ø 32 OD	ø 32 OD	ø 32 OD	ø 32 OD
<b>Packing Measurements</b>	m <sup>3</sup>	0.23	0.23	0.23	0.23	0.37	0.37
<b>Adaptable Air Panel</b>	-	P-G23DWA1	P-G23DWA1	P-G23DWA1	P-G23DWA1	P-G46DWA1	P-G46DWA1
<b>Colour</b> (Munsell Code)	-	Spring white (4.1Y8.5 / 0.7)					
<b>Outer Dimensions</b>							
Height	mm	30+10	30+10	30+10	30+10	30+10	30+10
Width	mm	1100	1100	1100	1100	1660	1660
Depth	mm	710	710	710	710	710	710
<b>Net Weight</b>	kg	6	6	6	6	8	8
<b>Packing Measurements</b>	m <sup>3</sup>	0.10	0.10	0.10	0.10	0.15	0.15
<b>Remote Control Switch</b>	-	PC-P2HTE / PC-LH3A					

### NOTES:

OD: Outer Diameter

1. The nominal cooling and heating capacity is the combined capacity of the HITACHI standard split system, and are based on the JISB 8616.

#### Cooling Operation Conditions

Indoor Air Inlet Temperature: 27.0 °C DB  
19.0 °C WB  
Outdoor Air Inlet Temperature: 35.0 °C DB

#### Heating Operation Conditions

Indoor Air Inlet Temperature: 20.0 °C DB  
Outdoor Air Inlet Temperature: 7.0 °C DB  
6.0 °C WB

#### Piping Length: 7.5 meters

DB: Dry Bulb; WB: Wet Bulb

2. The Sound Pressure Level is based on the following conditions:

- 1.5 meters Beneath the Unit.

- Voltage of the power source for the indoor fan motor is 230V.

The above data was measured in an anechoic chamber so that reflected sound should be taken into consideration when installing the unit.

## RPC-FSN2E Technical Description

- Stylish design
- Space saving design
- Easy installation
- Quiet operation

The RPC ceiling type indoor unit is simple to install, has an elegant design, an automatic swing louver and is very quiet in operation

### Elegant design

An innovative fan and heat exchanger design led to the creation of today's ultra slim ceiling unit. Fully adjustable mounting brackets allow the unit to be fitted flush with the ceiling leaving a profile of only 150mm.

### Simple and flexible installation

To expand the installation and positioning options the unit has a choice of two drain pipe connections, also refrigeration pipes can be connected to the left, right or rear of the unit.

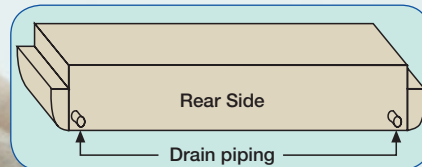

### Automatic swing louver

A highly efficient, multi blade centrifugal fan generates that along with the automatic swing louver generates a powerful yet gentle airflow evenly distributed throughout the room ensuring comfort and extremely quiet operation.

## Ceiling suspended

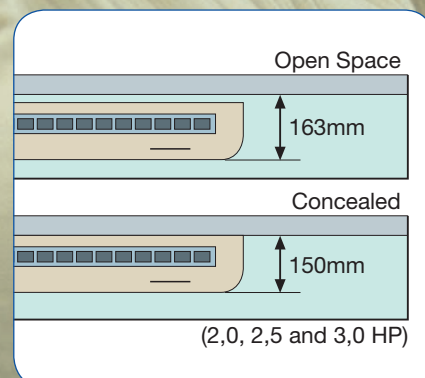

## General Data

Model	Units	RPC-2.0FSN2E	RPC-2.5FSN2E	RPC-3.0FSN2E	RPC-4.0FSN2E	RPC-5.0FSN2E	RPC-6.0FSN2E
<b>Nominal Cooling Capacity</b>	kW	5.00	6.30	7.10	10.00	12.50	14.00
<b>Nominal Heating Capacity</b>	kW	5.60	7.00	8.00	11.20	14.00	16.00
<b>Air Flow Rate</b> (hi/me/lo)	m <sup>3</sup> /min	15/13/10	18/16/12	21/17/15	30/24/19	35/28/21	37/32/27
<b>Fan Motor</b>	W	75	75	75	145	145	145
<b>Sound Pressure Level</b> (Overall A Scale) (hi/me/lo)	dB(A)	44/42/38	46/43/41	48/45/42	49/45/39	49/46/41	50/48/44
<b>Outer Dimensions</b>							
Height	mm	163	163	163	225	225	225
Width	mm	1094	1314	1314	1314	1574	1574
Depth	mm	625	625	625	625	625	625
<b>Net Weight</b>	kg	28	31	31	35	41	41
<b>Colour</b>	Spring White (4.1Y8.5 / 0.7)						
<b>Refrigerant</b>	R410A (Nitrogen Charged in Factory for Corrosion-Resistance)						
<b>Connections</b>	Connection with Flare-Nuts						
<b>Refrigerant-Piping</b>							
Liquid Line	mm(in.)	ø 6.35 (1/4)	ø 9.53 (3/8)	ø 9.53 (3/8)	ø 9.53 (3/8)	ø 9.53 (3/8)	ø 9.53 (3/8)
Gas Line	mm(in.)	ø 15.88 (5/8)	ø 15.88 (5/8)	ø 15.88 (5/8)	ø 15.88 (5/8)	ø 15.88 (5/8)	ø 15.88 (5/8)
Condensate Drain	mm	ø 25 OD	ø 25 OD	ø 25 OD	ø 25 OD	ø 25 OD	ø 25 OD
<b>Packing Measurements</b>	m <sup>3</sup>	0.24	0.29	0.29	0.36	0.43	0.43
<b>Remote Control Switch</b>	-	PC-ART/PC-P2HTE					

### NOTES:

**OD:** Outer Diameter

1. The nominal cooling and heating capacity is the combined capacity of the HITACHI standard split system, and are based on the ISO 5151.

\*R410A (Std. Accessory pipe to be used)

#### Cooling Operation Conditions

Indoor Air Inlet Temperature: 27.0 °C DB  
19.0 °C WB  
Outdoor Air Inlet Temperature: 35.0 °C DB

#### Heating Operation Conditions

Indoor Air Inlet Temperature: 20.0 °C DB  
Outdoor Air Inlet Temperature: 7.0 °C DB  
6.0 °C WB

**Piping Length:** 7.5 meters

**Piping Lift:** 0 meter

**DB:** Dry Bulb; **WB:** Wet Bulb

2. The Sound Pressure Level is based on the following conditions:

- 1 meter beneath the Unit, 1 meter from Discharge grill.

- Voltage of the power source for the indoor fan motor is 230V.

The above data was measured in an anechoic chamber so that reflected sound should be taken into consideration when installing the unit.

## RPI-FSN2E Technical Description

- Slim design
- Adjustable fan speed
- Adjustable static pressure
- Drain Pump as standard
- Air Filter as standard

The RPI in the ceiling type indoor unit is designed especially for installation in false ceiling spaces.

### Slim but sturdy design

The RPI has a reinforced structure to give the unit more rigidity when it is suspended. It also only requires a small amount of space due to the reduction in overall dimensions and has one of the lowest height in the market, allowing it to be installed in practically any existing false ceiling or ducted space with out substantial modification.

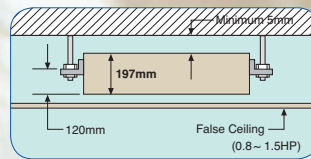

### Adjustable static pressure

The unit has 3 static pressure settings and can be adapted to suit the installation requirements. The high static pressure setting can be used for longer duct installations and the low static pressure setting for those installations with short duct lengths.

### Drain pump as standard (Only for 1.5~6.0 HP)

The units are equipped with an automatic internal drain pump, which removes the accumulated condensation from the drain pan. An electronic sensor monitors the water level activating the pump only when necessary.

### Intake filter as standard

To allow for situations where there is little or no intake ducting the RPI unit is equipped with an intake filter as standard. If the unit is connected to a longer duct it is possible to remove the filter or it can be left in place. The filter can be easily accessed and removed from the bottom for cleaning and maintenance without having to remove any ducting.

### Air Intake Direction

The direction of the air intake can be modified by interchanging the bottom panel with the fan cover allowing a horizontal or vertical air intake.

## Mini - In the ceiling (RPIM 1.5 FSN2E)

The new RPIM units have been designed specifically for situations where a reduced installation space is available. Coupled with exceptionally low noise levels this makes the range and should be an ideal choice for hotel applications.

## Econofresh Kit

As part of the Utopia range the Econofresh can provide up to 100% fresh air and has the ability to provide 'free cooling' via dampers when the outdoor ambient temperature is below the temperature required indoors. Available for 5.0HP unit.



## In-the-ceiling



## General Data

Model	Units	RPI-1.5 FSN2E	RPI-2.0 FSN2E	RPI-2.5 FSN2E	RPI-3.0 FSN2E	RPI-4.0 FSN2E	RPI-5.0 FSN2E	RPI-6.0 FSN2E	RPIM-1.5 FSN2E
<b>Nominal Cooling Capacity</b>	kW	3.60	5.00	6.30	7.10	10.00	12.50	14.00	3.60
<b>Nominal Heating Capacity</b>	kW	4.00	5.60	7.00	8.00	11.20	14.00	16.00	4.00
<b>Air Flow Rate</b>									
(Hi/Me/Lo) to (SP-00)	m³/min	10/10/9	16/15/13	19/17/15	22/20/17	30/28/25	35/32/28	36/33/29	10/10/8.5
<b>Static Pressure</b>									
(Hi) at (SP-01/SP-00/SP-02)	Pa	40/25/25	80/50/25	80/50/25	120/80/40	120/80/25	120/80/25	120/80/25	45/10
<b>Fan Motor</b>	W	40	50	50	215	200	215	365	33
<b>Sound Pressure Level</b>									
(Hi/Me/Lo) at (SP-00)	dB(A)	34/34/31	33/31/29	35/33/30	35/35/31	37/36/35	39/38/36	40/39/38	33/29
<b>Sound Power Level</b>	dB(A)	56	59	60	60	62	63	64	51
<b>Outer Dimensions</b>									
Height	mm	197	275	275	275	275	275	275	275
Width	mm	1084	1084	1084	1084	1474	1474	1474	702
Depth	mm	600	600	600	600	600	600	600	600
<b>Net Weight</b>	kg	29,5	35	37	37	48	49	49	26
<b>Refrigerant</b>	R410A (Nitrogen Charged in Factory for Corrosion-Resistance)								
<b>Connections</b>	Connection with Flare Nuts								
<b>Refrigerant-Piping</b>									
Liquid Line	mm(in.)	Ø 6.35 (1/4)	Ø 6.35 (1/4)	Ø 9.53 (3/8)	Ø 9.53 (3/8)	Ø 9.53 (3/8)	Ø 9.53 (3/8)	Ø 9.53 (3/8)	Ø 6.35 (1/4)
Gas Line	mm(in.)	Ø 12.7 (1/2)	Ø 15.88 (5/8)	Ø 15.88 (5/8)	Ø 15.88 (5/8)	Ø 15.88 (5/8)	Ø 15.88 (5/8)	Ø 15.88 (5/8)	Ø 12.7 (1/2)
Condense Drain	mm	Ø 32 OD	Ø 32 OD	Ø 32 OD	Ø 32 OD	Ø 32 OD	Ø 32 OD	Ø 32 OD	Ø 25 OD
<b>Packing Measurements</b>	m³	0.18	0.25	0.25	0.25	0.33	0.33	0.33	0.17
<b>Standard accessories</b>	-	Air Filter, Drain Pump							
<b>Remote Control Switch</b>	-	PC-ART/PC-P2HTE							

## NOTES:

1. The nominal cooling and heating capacity is the combined capacity of the HITACHI standard split system, and are based on the ISO 5151.

### Cooling Operation Conditions

Indoor Air Inlet Temperature: 27.0 °C DB  
19.0 °C WB  
Outdoor Air Inlet Temperature: 35.0 °C DB

### Heating Operation Conditions

Indoor Air Inlet Temperature: 20.0 °C DB  
Outdoor Air Inlet Temperature: 7.0 °C DB  
6.0 °C WB

### Piping Length: 7.5 meters

Piping Lift: 0 meter  
DB: Dry Bulb; WB: Wet Bulb

### OD: Outer Diameter

SP: Static Pressure Connection

### Hi/Me/Lo: Fan Speed

2. The Sound Pressure Level is based on the following conditions:

- 1.5 meter Beneath the Unit (without ceiling under the unit), applying suction duct 1m. and discharge duct 2m.
- Voltage of the power source for the indoor fan motor is 230V.

The above data was measured in an anechoic chamber so that reflected sound should be taken into consideration when installing the unit.

Model	EF-5GE
<b>Combined Indoor Unit Model</b>	RPI-5FSN1E
<b>Outer Dimensions</b>	
Height	mm 254
Width	mm 1350 + 59
Depth	mm 270
<b>Net Weight</b>	Kg 12.5
<b>Damper Motor Quality</b>	1
<b>Approximate Packing Measurement</b>	m³ 0.13
<b>Standard Accessories</b>	Fresh Outdoor Air Inlet Thermistor

## RPK-FSN2M Technical Description

- Stylish Design
- Easy Maintenance
- Compact & Lightweight Design

### **Stylish Design and Easy Maintenance**

New flat panel design across all models. This flat panel allows for easy maintenance.

### **Compact and Light Weight Design**

Designed with ease of installation in mind this new space saving model also uses a high proportion of light weight parts reducing the unit weight. The new 1.0HP and 1.5HP models have a reduced weight of just 10kg.

### **Wireless or Wired Control**

The indoor unit is equipped with a wireless receiver kit inside as a standard accessory. The wired remote control switch, PC-P1HE is also applicable. Easy switching from wireless to wired remote controller is possible by using the dip switch built into the receiver part.

# Wall mounted





## General Data

Model		RPK-1.0FSN2M	RPK-1.5FSN2M	RPK-2.0FSN2M	RPK-2.5FSN2M	RPK-3.0FSN2M	RPK-4.0FSN2M
<b>Indoor Unit Power Supply</b>		AC 1Ø, 230V / 50Hz					
<b>Nominal Cooling Capacity</b>	kW	2.8	4.5	5.6	7.1	8.0	11.2
<b>Nominal Heating Capacity</b>	kW	3.2	5.0	6.3	8.5	9.0	12.5
<b>Sound Pressure Level</b> (Overall Scale) (hi/me/lo)	dB(A)	38/36/34	40/38/36	41/39/37	43/40/37	43/40/37	49/46/43
<b>Outer Dimensions</b>							
Height	mm	280	280	295	333	333	333
Width	mm	780	780	1030	1150	1150	1150
Depth	mm	210	210	208	245	245	245
<b>Net Weight</b>	kg	10	10	12	18	18	18
<b>Refrigerant</b>	–	R410 A (Nitrogen Charged in Factory for Corrosion-resistance)					
<b>Air Flow Rate</b> (hi/me/lo)	m <sup>3</sup> /min	10/8/7	11/10/9	14/12/10	17/16/14	17/16/14	22/20/17
<b>Fan Motor</b>	W	20	20	30	30	30	30
<b>Connections</b>	–	Flare-Nut Connection (with Flare-Nuts)					
<b>Refrigerant-Piping</b>							
Liquid Line	mm(in)	ø 6.35 (1/4)	ø 6.35 (1/4)	ø 6.35 (1/4)	ø 9.53 (3/8)	ø 9.53 (3/8)	ø 9.53 (3/8)
Gas Line	mm(in)	ø 12.7 (1/2)	ø 12.7 (1/2)	ø 15.88 (5/8)	ø 15.88 (5/8)	ø 15.88 (5/8)	ø 15.88 (5/8)
Condensate Drain	–	VP16	VP16	VP16	VP16	VP16	VP16
<b>Packing Measurements (approx.)</b>	m <sup>3</sup>	0.07	0.07	0.11	0.13	0.13	0.13
<b>Remote Control Switch</b>		PC-P2HTE or PC-LH3A					

### NOTES:

OD: Outer Diameter

1. The nominal cooling and heating capacity is the combined capacity of the HITACHI standard split system, and are based on the JISB 8616.

#### Cooling Operation Conditions

Indoor Air Inlet Temperature: 27.0 °C DB  
19.0 °C WB  
Outdoor Air Inlet Temperature: 35.0 °C DB

#### Heating Operation Conditions

Indoor Air Inlet Temperature: 20.0 °C DB  
Outdoor Air Inlet Temperature: 7.0 °C DB  
6.0 °C WB

#### Piping Length: 7.5 meters

DB: Dry Bulb; WB: Wet Bulb

2. The Sound Pressure Level is based on the following conditions:

- 1.0 meters Beneath the Unit, 1.0 meters from discharge grille.
- Voltage of the power source for the indoor fan motor is 230V.

The above data was measured in an anechoic chamber so that reflected sound should be taken into consideration when installing the unit.

## RPF/RPFI-FSN2E Technical Description

### Floor mounted indoor units – RPF

- Floor type
- Slim design, only 220mm deep
- Low height, only 630mm
- Light unit
- Low sound level

### Floor Mounted – cased

#### Space Saving Slim Unit

This unit's slim line design with a depth of only 220mm allows the unit to be freely installed without spoiling the aesthetics of a room.

#### Effective use of space

With a height of only 630mm it is possible to install under or by a window while still leaving plenty of space.

#### Optional Location for Remote Control Switch

It is also possible to conceal the remote controller as there is space to install a PC-P2HT inside the casing.

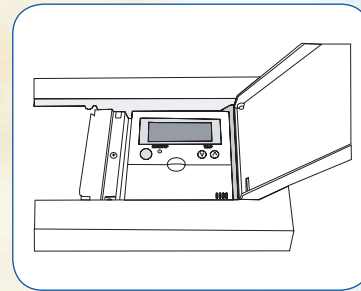

## Floor mounted

### Floor concealed indoor units – RPFI

- Compact design
- 620mm in height
- 220mm in depth

### Floor Mounted – uncased

#### Compact Design

Special emphasis has been placed on compatibility with interior design. The space saving design 620mm in height, 220mm in depth, fits perfectly into the space below bay windows.

#### Air Discharge Direction

The Air discharge direction can be modified by repositioning the back cover allowing for more installation options.



## General Data

Model	Units	RPF-1.5FSN2E	RPF-2.0FSN2E	RPF-2.5FSN2E	RPFI-1.5FSN2E	RPFI-2.0FSN2E	RPFI-2.5FSN2E
<b>Nominal Cooling Capacity</b>	kW	3.60	5.00	6.30	3.60	5.00	6.30
<b>Nominal Heating Capacity</b>	kW	4.00	5.60	7.00	4.00	5.60	7.00
<b>Air Flow Rate</b> (hi/me/lo)	m <sup>3</sup> /min	12/10/9	16/14/11	16/14/11	12/10/9	16/14/11	16/14/11
<b>Fan Motor</b>	W	28	45	45	28	45	45
<b>Sound Pressure Level</b> (Overall A Scale) (hi/me/lo)	dB(A)	38/35/31	39/36/32	42/38/34	38/35/31	39/36/32	42/38/34
<b>Outer Dimensions</b>							
Height	mm	630	630	630	620	620	620
Width	mm	1170	1420	1420	988	1238	1238
Depth	mm	220	220	220	220	220	220
<b>Net Weight</b>	kg	28	33	34	23	27	28
<b>Colour</b>	-	Spring White (4.1Y 8.5 / 0.7)					
<b>Refrigerant</b>	R410A (Nitrogen Charged in Factory for Corrosion-Resistance)						
<b>Connections</b>	Connection with Flare Nuts						
<b>Refrigerant-Piping</b>							
Liquid Line	mm(in)	ø 6.35 (1/4)	ø 6.35 (1/4)	ø 9.53 (3/8)	ø 6.35 (1/4)	ø 6.35 (1/4)	ø 9.53 (3/8)
Gas Line	mm(in)	ø 12.7 (1/2)	ø 15.88 (5/8)	ø 15.88 (5/8)	ø 12.7 (1/2)	ø 15.88 (5/8)	ø 15.88 (5/8)
Condensate Drain	mm	ø 18.5 OD	ø 18.5 OD	ø 18.5 OD	ø 18.5 OD	ø 18.5 OD	ø 18.5 OD
<b>Packing Measurements</b>	m <sup>3</sup>	0.24	0.29	0.29	0.23	0.25	0.25
<b>Remote Control Switch</b>	-	PC-ART/PC-P2HTE					

### NOTES:

OD: Outer Diameter

1. The nominal cooling and heating capacity is the combined capacity of the HITACHI standard split system, and are based on the ISO 5151.

#### Cooling Operation Conditions

Indoor Air Inlet Temperature: 27.0 °C DB  
19.0 °C WB  
Outdoor Air Inlet Temperature: 35.0 °C DB

#### Heating Operation Conditions

Indoor Air Inlet Temperature: 20.0 °C DB  
Outdoor Air Inlet Temperature: 7.0 °C DB  
6.0 °C WB

Piping Length: 7.5 meters

Piping Lift: 0 meter

DB: Dry Bulb; WB: Wet Bulb

2. The Sound Pressure Level is based on the following conditions:

- 1 meter from the unit, 1 meter from floor level.

- Voltage of the power source for the indoor fan motor is 230V.

The above data was measured in an anechoic chamber so that reflected sound should be taken into consideration when installing the unit.

## Utopia ES Technical Description

- Compact Design
- Common cabinet size and exterior
- Environmentally friendly

The Utopia ES units are the latest addition to the Utopia range of Hitachi air conditioners. This cost effective range is available in 3/4/5/6 HP models.

### Compact Design

The 'ES' range is small and compact; the 4HP/5HP/6HP models have only one fan.

### Common cabinet size and exterior

Common cabinet size and exterior of the Utopia IVX and Utopia ES allows for the units to be installed together creating a uniformed appearance.

### Improved EER figures

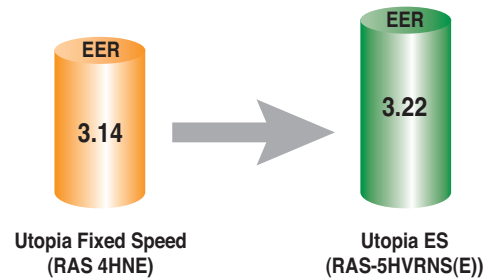

### Compatibility

Compatible with all Hitachi System Free indoor units.

# Utopia ES



## General Data

Model		RAS-3HVRNS	RAS-4HVRNSE	RAS-5HVRNSE	RAS-6HVRNSE
<b>Power Supply</b>		AC 1φ, 230V / 50Hz			
<b>Cooling Capacity</b> (Min./Nomi./Max.)	kW	1.5/7.1/8.0	4.9/10.0/11.2	5.7/12.5/14.0	6.0/14.0/16.0
<b>Heating Capacity</b> (Min./Nomi./Max.)	kW	1.5/8.0/9.0	5.0/11.2/12.5	6.0/14.0/16.0	6.0/16.0/18.0
<b>Sound Pressure Level</b> (Cooling/Night-Shift/Heating)	dB(A)	48/46/50	44/40/46	46/42/48	48/45/50
<b>Outer Dimensions</b>					
Width	mm	792(+95)	950	950	950
Depth	mm	300	370	370	370
Height	mm	600	800	800	800
<b>Net Weight</b>	kg	44	85	89	89
<b>Gross Weight</b>	kg	49	90	94	94
<b>Refrigerant</b>		R410A	R410A	R410A	R410A
<b>Refrigerant Charge</b> (Factory)	kg	1.9	2.8	3.3	3.3
<b>Chargeless Length</b>	m	20	30	30	30
<b>Max. Refrigerant Piping Length</b>	m	30	50	50	50
<b>Max. Height Difference</b>	m	30 (20 If the Outdoor Unit is installed lower than Indoor Unit)			
<b>Oil Type</b>		HAF68D1 or 68HES-H(Ester)	FVC68D (Ether)	FVC68D (Ether)	FVC68D (Ether)
<b>Oil Charge</b>	L	0.75	1.2	1.2	1.2
<b>Outdoor Fan Air Flow Rate</b>	m <sup>3</sup> /min	41	62	80	80
<b>Motor Output</b>	W	40	74	170	170
<b>Recommended Fuse Size</b>	A	25	32	32	32
<b>Refrigerant-Piping</b>					
Liquid Line	mm(in.)	ø 9.53 (3/8)	ø 9.53 (3/8)	ø 9.53 (3/8)	ø 9.53 (3/8)
Gas Line	mm(in.)	ø 15.88 (5/8)	ø 15.88 (5/8)	ø 15.88 (5/8)	ø 15.88 (5/8)
Approximate Packing Measurement	m <sup>3</sup>	0.26	0.43	0.43	0.43
<b>Working Range</b> (Cool)	°C	-5~43(Outdoor) (DB)	-5~43(Outdoor) (DB)	-5~43(Outdoor) (DB)	-5~43(Outdoor) (DB)
<b>Working Range</b> (Heat)	°C	-10~15(Outdoor) (WB)	-10~15(Outdoor) (WB)	-10~15(Outdoor) (WB)	-10~15(Outdoor) (WB)

### NOTES:

1. The nominal cooling and heating capacity is the combined capacity of the HITACHI standard split system, and are based on the ISO 5151.

#### Cooling Operation Conditions

Indoor Air Inlet Temperature: 27.0 °C DB  
19.0 °C WB

Outdoor Air Inlet Temperature: 35.0 °C DB

#### Heating Operation Conditions

Indoor Air Inlet Temperature: 20.0 °C DB

Outdoor Air Inlet Temperature: 7.0 °C DB  
6.0 °C WB

#### Piping Length: 7.5 meters

**DB:** Dry Bulb; **WB:** Wet Bulb

2. The Sound Pressure Level is based on the following conditions:

- Voltage of the power source is 230V.
- The above Sound Pressure data was measured in an anechoic chamber so that reflected sound should be taken into consideration when installing the unit.

### Combination Table

Connection Condition	3HP		4HP		5HP		6HP		
Single	3.0		4.0		5.0		6.0		
Twin	1.5	1.5	2.0	2.0	2.5	2.5	3.0	3.0	
Triple							2.0	2.0	2.0

## Utopia IVX Technical Description

- Compact and Lightweight
- Minimum use of refrigerant
- Wide operating range down to -5° cooling and -20° heating
- Individual unit control
- Award winning Energy Efficiency – High COP of 4.41 (8HP models)

The Utopia IVX is a very efficient product boasting an extremely high COP of 4.41 (8HP models) and is a further development on its predecessor which was presented the “Shoene Taishou” (Energy Efficiency Award) by the Japanese Government. The unit uses a horizontal discharge twin fan design allowing for a more efficient use of floor space and is available from 7.1kW to 30kW models.

### Greater Installation Flexibility

The IVX changes the way we think about twin, triple and quad split configurations and is the perfect choice for installations requiring individual unit control but have no need for the piping length capabilities available with more expensive VRF systems.

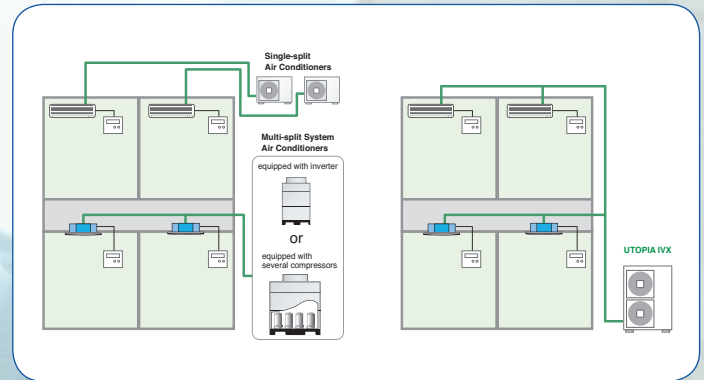

### More Efficient Control

By the use of individual control we can create a more comfortable environment for rooms that have unbalanced loads. This also leads to more economical operation as units not requiring operation will stop, reducing wasted energy.

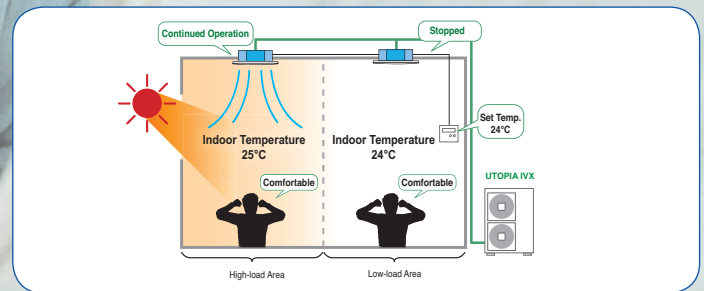

# Utopia IVX



### Combination Table

Model	3HP		4HP		5HP		6HP	
<b>Single</b>	3.0		4.0		5.0		6.0	
<b>Twin</b>	1.5	1.5	2.0	2.0	2.5	2.5	3.0	3.0
			2.3	1.8	3.0	2.3		
			2.5	1.8				
<b>Triple</b>			1.5	1.5	1.5	1.8	1.8	1.5
			1.5	1.5	1.3			2.0
			1.3	1.3	1.5			2.0
								1.8
								1.8
								2.0

**NOTES:** The indoor unit 1.8HP and 2.3HP are not available. Please change the 2HP and 2.5HP indoor units Dip Switch setting according to the above.

## General Data

Model	RAS-3HVRNME	RAS-4HVRNME	RAS-5HVRNME	RAS-6HVRNME	RAS-4HRNME	RAS-5HRNME	RAS-6HRNME	RAS-8HRNM	RAS-10HRNM	RAS-12HRNM		
<b>Power Supply</b>	AC 1ø, 230V / 50Hz				AC 3ø 400V 50Hz			380-415V/50Hz				
<b>Cooling Capacity</b> (Min./Nomi./Max.)	kW	3.2/7.1/8.0	4.9/10.0/11.2	5.7/12.5/14.0	6.0/14.0/16.0	4.9/10.0/11.2	5.7/12.5/14.0	6.0/14.0/16.0	9.0/20.0/22.4	11.2/25.0/28.0	13.5/30.0/33.5	
<b>Heating Capacity</b> (Min./Nomi./Max.)	kW	3.5/8.0/10.6	5.0/11.2/14.0	5.0/14.0/18.0	5.0/16.0/20.0	5.0/11.2/14.0	5.0/14.0/18.0	5.0/16.0/20.0	8.3/22.4/28.0	10.5/28.0/35.0	12.6/33.5/37.5	
<b>Cabinet Colour</b> (Munsell Code)	-	Natural Grey				Natural Grey			Natural Grey			
<b>Sound Pressure Level</b> (Cooling/Night-Shift/Heating)	kW	42/38/44	44/40/46	46/42/48	48/45/50	44/40/46	46/42/48	48/45/50	52 (50)/54	55 (53/57)	58 (55)/60	
<b>Outer Dimensions</b>												
Width	mm	950	950	950	950	950	950	950	1100	1100	1745	
Depth	mm	370	370	370	370	370	370	370	390	390	390	
Height	mm	800	1380	1380	1380	1380	1380	1380	1650	1650	1650	
<b>Net Weight</b>	kg	67	114	115	115	119	120	120				
<b>Gross Weight</b>	kg	74	119	120	120	124	125	125	170	170	173	
<b>Refrigerant</b>		R410A				R410A			R410A Micro Crontrrolled Expansion Valve			
<b>Refrigerant Charge</b> (Factory)	kg	2.4	3.9	4.0	4.0	3.9	4.0	4.0				
<b>Compressor</b>		DC Inverter Driven Compressor				DC Inverter Driven Compressor			DC Inverter Driven Compressor			
<b>Model</b>		2YC45DXD	E306AD	E406AHD	E406AHD				E655DHD-65D2			
<b>Quantity</b>		1	1	1	1	1	1	1	1	1	1	
<b>Heat Exchanger</b>		Multipass Cross Finned Tube				Multipass Cross Finned Tube			Multipass Cross Finned Tube			
<b>Condenser Fan</b>		Propeller Fan				Propeller Fan			Propeller Fan			
<b>Quantity</b>		1	2	2	2	2	2	2	2	2	2	
<b>Air Flow Rate</b>	m³/min	45	80	90	100	80	90	100	121	150	163	
<b>Chargeless Length</b>	m	30	30	30	30	30	30	30	-	-	-	
<b>Max. Refrigerant Piping Length</b>	m	50	70	75	75	70	75	75	-	-	-	
<b>Max. Height Difference</b>	m	30 (20m if the outdoor unit is installed lower than indoor unit)				30 (20m if the outdoor unit is installed lower than indoor unit)			30 (20m if the outdoor unit is installed lower than indoor unit)			
<b>Oil Type</b>		FVC50K	FVC68D	FVC68D	FVC68D	FVC68D	FVC68D	FVC68D	-	-	-	
<b>Oil Charge</b>	L	0.65	1.2	1.2	1.2	1.2	1.2	1.2	-	-	-	
<b>Outdoor Fan Air Flow Rate</b>	m³/min	45	80	90	100	80	90	100	-	-	-	
<b>Motor</b>	W	74	74+74	74+74	74+74	74+74	74+74	74+74	170+120	170+170	170+200	
<b>Recommended Fuse Size</b>	A	25	32	32	32	20	20	20	-	-	-	
<b>Refrigerant-Piping</b>									Flare-nut Connection (factory supplied)			
Liquid Line	mm(in.)	ø 9.53 (3/8)	ø 9.53 (3/8)	ø 9.53 (3/8)	ø 9.53 (3/8)	ø 9.53 (3/8)	ø 9.53 (3/8)	ø 9.53 (3/8)	ø 9.53 (3/8)	ø 12.7 (1/2)	ø 12.7 (1/2)	
Gas Line	mm(in.)	ø 15.88 (5/8)	ø 15.88 (5/8)	ø 15.88 (5/8)	ø 15.88 (5/8)	ø 15.88 (5/8)	ø 15.88 (5/8)	ø 15.88 (5/8)	ø 25.4 (1)*1	ø 25.4 (1)	ø 25.4 (1)	
Approximate Packing Measurement	m³	0.43	0.70	0.70	0.70	0.70	0.70	0.70	1.44	1.44	1.44	
<b>Maximum Pipe Length</b>	m	50	70	75	75	70	75	75		100		
<b>Height Difference between indoor units</b>	m	-	-	-	-	-	-	-		≥3		
<b>Height Difference</b> between 1st branch kit & indoor units	m	-	-	-	-	-	-	-		≥15		
<b>Height Difference</b> between indoor unit and outdoor unit	m	-	-	-	-	-	-	-		outdoor unit higher than indoor unit ≥30 outdoor unit lower than indoor unit ≥20		
<b>Refrigerant Charge</b> (30m chargeless)	kg	2.4	3.9	4.0	4.0	3.9	4.0	4.0	7.3	7.8	8.5	
<b>Control Circuit</b>	mm	-	-	-	-	-	-	-	0.75	0.75	0.75	
<b>Connecting Wires Between Outdoor and Indoor Unit</b>		-	-	-	-	-	-	-	2	2	2	
<b>Working Range</b> (Cool)	°C		-5~46 (Outdoor) (DB)				-5~46 (Outdoor) (DB)					
<b>Working Range</b> (Heat)	°C		-20~15 (Outdoor) (WB)				-20~15 (Outdoor) (WB)					

Model	8HP						10HP						12HP						
<b>Single</b>	8.0						10.0						-						
<b>Twin</b>	4.0/4.0			5.0/3.0			5.0/5.0			6.0/4.0			6.0/6.0						
<b>Triple</b>	3.0/3.0/2.3	3.0/3.0/2.5	3.0/3.0/3.0	3.0/2.5/2.5	3.0/3.0/3.0			4.0/3.0/3.0			4.0/4.0/4.0								
<b>Quad</b>	2.0/ 2.0/ 2.0/ 2.0	2.0/ 2.0/ 2.3/ 1.8	2.0/ 1.8/ 2.5/ 1.8	2.3/ 1.8/ 2.5/ 1.8	2.3/ 1.8/ 2.5/ 1.8	2.5/ 1.8/ 2.5/ 1.8	2.5/ 2.5/ 2.5/ 2.5	2.5/ 2.5/ 3.0/ 2.0	2.5/ 2.5/ 3.0/ 2.0	2.5/ 2.5/ 3.0/ 2.0	3.0/ 2.3/ 3.0/ 2.3	3.0/ 2.3/ 3.0/ 2.0	3.0/ 2.0/ 3.0/ 3.0	3.0/ 3.0/ 3.0/ 3.0	3.0/ 3.0/ 4.0/ 2.3	3.0/ 2.5/ 3.0/ 2.5	3.0/ 2.5/ 4.0/ 2.3	3.0/ 2.5/ 4.0/ 2.3	4.0/ 2.3/ 4.0/ 2.3
	2.5/ 2.0/ 2.0/ 1.8	2.5/ 2.0/ 2.0/ 2.0					3.0/ 2.5/ 3.0/ 2.0	3.0/ 2.5/ 2.5/ 2.5				4.0/ 2.5/ 3.0/ 3.0	4.0/ 2.5/ 3.0/ 2.5						

## Utopia DC Inverter Technical Description

- Compact design
- DC Fan Motor
- High efficiency Scroll Compressor
- Improved refrigerant cycles (Gas Injection Cycle)

The Utopia DC Inverter range is available from 5.0-14kW cooling (nominal) giving high COP's for extremely efficient operating costs.

### Compatibility

Compatible with all Hitachi System Free indoor units.

### DC Fan Motor with Outstanding Efficiency

The DC fan motor greatly improves efficiency compared to conventional products using an AC motor. Also, air blasts are reduced by controlling the rotation speed of the fan. Stable operation is provided against strong head winds of approximately 10 m/s on the front face of the outdoor unit.

### New Gas Injection System

New high pressure gas injection directly to the compressor improves cycle efficiency and reduces compressor input (except for RAS-2/2.5/3H(V)RNE).

### Inverter control

The inverter controls compressor speeds from 30 Hz to 115 Hz, quickly reaching the set temperature and maintaining a stable energy-saving operation.

# Utopia DC Inverter





## General Data

Model		RAS-2HVRN1	RAS-2.5HVRN1	RAS-3HVRNE	RAS-4HVRNE	RAS-5HVRNE	RAS-4HRNE	RAS-5HRNE	RAS-6HRNE	
<b>Power Supply</b>		AC 1ø 230V 50Hz					AC 3ø 400V 50Hz			
<b>Nominal Cooling Capacity</b> (Max/Nom/Min)	kW	5.6/ <b>5.0</b> /2.2	6.3/ <b>6.0</b> /2.2	8.00/ <b>7.10</b> /3.90	11.20/ <b>10.00</b> /4.90	14.0/ <b>12.50</b> /6.70	11.2/ <b>10.0</b> /4.9	14.0/ <b>12.5</b> /6.7	16.0/ <b>14.0</b> /6.9	
<b>Nominal Heating Capacity</b> (Max/Nom/Min)	kW	7.1/ <b>5.6</b> /2.2	7.1/ <b>7.0</b> /2.2	10.0/ <b>8.00</b> /4.0	14.0/ <b>11.20</b> /5.7	18.0/ <b>14.00</b> /7.0	14.0/ <b>11.2</b> /5.7	18.0/ <b>14.0</b> /7.0	19.4/ <b>16.0</b> /8.1	
<b>Cabinet Colour</b> (Munsell Code)	-	Natural Grey (1.0Y8.5/0.5)								
<b>Sound Pressure Level</b> (Night Shift)	dB (A)	48/(44)	48/(44)	43/(39)	45/(41)	47/(43)	45/(41)	47/(43)	48/(44)	
<b>Outer Dimensions</b>										
Height	mm	600	600	800	1240	1240	1240	1240	1240	
Width	mm	792(+95)	792(+95)	850	950	950	950	950	950	
Depth	mm	300	300	315	315	315	315	315	315	
<b>Net Weight</b>	kg	42	42	60	95	97	100	102	102	
<b>Refrigerant Flow Control</b>	-	R410A Micro-Computer Controlled Expansion Valve								
<b>Compressor</b>		Hermetic (Scroll)	Hermetic (Scroll)	Hermetic (Rotary)	Hermetic (Scroll)	Hermetic (Scroll)	Hermetic (Scroll)	Hermetic (Scroll)	Hermetic (Scroll)	
Model	-	EU1114D6	EU1114D6	2YC45BXD	E305AHD	E405AHD	E305AHD	E405AHD	E405AHD	
Quantity	-	1	1	1	1	1	1	1	1	
Motor Output	kW	0.95	1.1	1.38 (4)	2.2 (4)	3.00 (4)	2.2 (4)	3.0 (4)	3.0 (4)	
<b>Heat Exchanger</b>		Multi-Pass Cross-Finned Tube								
<b>Condenser Fan</b>	-			Propeller Fan			Propeller Fan			
Quantity	-	1	1	1	2	2	2	2	2	
Air Flow Rate	m³/min	35	35	45	80	90	80	90	100	
Motor Output (Pole)	W	40	40	50(8)	30(8) + 50(8)	50(8) + 70(8)	30(8) + 50(8)	50(8) + 70(8)	50(8) + 70(8)	
<b>Connections</b>		Flare-Nut and/or Flange Connection (Factory supplied)								
<b>Refrigerant-Piping</b>										
Liquid Line	mm(in.)	ø 6.35 (1/4)	ø 6.35 (1/4)	ø 9.53 (3/8)	ø 9.53 (3/8)	ø 9.53 (3/8)	ø 9.53 (3/8)	ø 9.53 (3/8)	ø 9.53 (3/8)	
Gas Line	mm(in.)	ø 12.7 (1/2)	ø 12.7 (1/2)	ø 15.88 (5/8)	ø 15.88 (5/8)	ø 15.88 (5/8)	ø 15.88 (5/8)	ø 15.88 (5/8)	ø 15.88 (5/8)	
<b>Refrigerant Charge</b>	kg	1.6	1.6	2.4	3.6	3.6	3.6	3.6	3.6	
<b>Wiring Holes</b>										
Power Supply	mm	-	-	ø 26.5	ø 26.5	ø 26.5	ø 26.5	ø 26.5	ø 26.5	
Control Circuit	mm	-	-	ø 26.5	ø 26.5	ø 26.5	ø 26.5	ø 26.5	ø 26.5	
<b>Connecting Wires Between Outdoor and Indoor Unit</b>	-	2	2	2	2	2	2	2	2	
<b>Packing Measurement</b>	m³	0.26	0.26	0.34	0.55	0.55	0.55	0.55	0.55	

### NOTES:

1. The nominal cooling and heating capacity is the combined capacity of the HITACHI standard split system, and are based on the ISO 5151.

#### Cooling Operation Conditions

Indoor Air Inlet Temperature: 27 °C DB (80 °F DB)  
19 °C WB (66.2 °F WB)  
Outdoor Air Inlet Temperature: 35 °C DB (95 °F DB)

#### Heating Operation Conditions

Indoor Air Inlet Temperature: 20 °C DB (68 °F DB)  
Outdoor Air Inlet Temperature: 7 °C DB (45 °F DB)  
6 °C WB (43 °F WB)

**Piping Length:** 7.5 meters  
**Piping Lift:** 0 Meter

The above data was measured in an anechoic chamber so that reflected sound should be taken into consideration in the field.

2. The sound pressure is based on the following conditions. 1 Meter from the unit service cover surface, and 1.5 Meters from floor level.

## Combination Table

Model	RAS-2HVRN1	RAS-2.5HVRN1	RAS-3HVRNE	RAS-4H(V)RNE	RAS-5H(V)RNE	RAS-6HRNE
<b>Single</b>	2.0	2.5	3.0	4.0	5.0	6.0
<b>Twin</b>	-	-	1.5/1.5	2.0/2.0	2.5/2.5	3.0/3.0
<b>Triple</b>	-	-	-	-	-	2.0/2.0/2.0

## Utopia Fixed Speed Technical Description

- Compact design and light weight
- R410A refrigerant
- Connectable to 'System Free' indoor units

The Utopia Fixed Speed range is available from 6.3kW to 12.5kW cooling (nominal)

### R410A Refrigerant

Using R410A refrigerant adds the following benefits:

- Reduced power consumption
- Increased system performance
- Higher heat exchange coefficient
- Reduction in component size

### Compact design & light weight

Extremely compact design enabling easy installation and effective use of plant space.

Hitachi has created one of the lightest and most compact systems on the market.

### Compatibility.

Compatible with all Hitachi System Free indoor units.

# Utopia Fixed Speed



## General Data

Model		RAS-2.5HNVE	RAS-3HNVE	RAS-4HNVE	RAS-2.5HNE	RAS-3HNE	RAS-4HNE	RAS-5HNE
<b>Power Supply</b>		AC 1ø 230V 50Hz			AC 3ø 400V 50Hz			
<b>Nominal Cooling Capacity</b> (Max/Nom/Min)	kW	6.30	7.10	10.00	6.30	7.10	10.0	12.5
<b>Nominal Heating Capacity</b> (Max/Nom/Min)	kW	7.00	8.00	11.20	7.00	8.00	11.2	14.0
<b>Cabinet Colour</b> (Munsell Code)	-	Natural Grey (1.0Y8.5/0.5)						
<b>Sound Pressure Level</b> (Night Shift)	dB (A)	47(46)	47(46)	47(46)	47(46)	47(46)	47(46)	47(46)
<b>Outer Dimensions</b>								
Height	mm	800	800	1240	800	800	1240	1240
Width	mm	850	850	950	850	850	950	950
Depth	mm	315	315	315	315	315	315	315
<b>Weight</b>	kg	66	69	90	66	69	90	90
<b>Refrigerant Flow Control</b> R410 A								
<b>Compressor</b>		Hermetic (Rotary)		Hermetic (Scroll)	Hermetic (Rotary)	Hermetic (Rotary)	Hermetic (Scroll)	Hermetic (Scroll)
<b>Model</b>		5JS290	5JS330	ZP41K3E	5JS290	5JS330	ZP41K3E	ZP57K3E
<b>Quantity</b>		1	1	1	1	1	1	1
<b>Motor Output</b>		1.9 (2)	2.2 (2)	3.0 (2)	1.9 (2)	2.2 (2)	3.0 (2)	3.75 (2)
<b>Heat Exchanger</b> Multi-Pass Cross-Finned Tube								
<b>Condenser Fan</b> Propeller Fan								
<b>Quantity</b>		1	1	2	1	1	2	2
<b>Air Flow Rate</b>	m³/min	40	46	70	40	46	70	103
<b>Motor Output</b> (Pole)	W	70	70	70x2	70	70	70x2	70x2
<b>Refrigerant-Piping</b> Flare-Nut Connection with Flare Nuts (factory supplied)								
Liquid Line	mm(in)	ø 9.53 (3/8)	ø 9.53 (3/8)	ø 9.53 (3/8)	ø 9.53 (3/8)	ø 9.53 (3/8)	ø 9.53 (3/8)	ø 9.53 (3/8)
Gas Line	mm(in)	ø 15.88 (5/8)	ø 15.88 (5/8)	ø 15.88 (5/8)	ø 15.88 (5/8)	ø 15.88 (5/8)	ø 15.88 (5/8)	ø 15.88 (5/8)
<b>Refrigerant Charge</b>	kg	2.3	2.5	3.6	2.3	2.5	3.6	3.6
<b>Wiring</b>								
Power Supply	mm	ø 26.5	ø 26.5	ø 26.5	ø 26.5	ø 26.5	ø 26.5	ø 26.5
Control Circuit	mm	ø 26.5	ø 26.5	ø 26.5	ø 26.5	ø 26.5	ø 26.5	ø 26.5
<b>Connecting Wires Between Outdoor and Indoor Unit</b>	-	2	2	2	2	2	2	2
<b>Packing Measurement</b>	m³	0.34	0.34	0.55	0.34	0.34	0.55	0.55

### NOTES:

1. The nominal cooling and heating capacity is the combined capacity of the HITACHI standard split system, and are based on the ISO 5151.

#### Cooling Operation Conditions

Indoor Air Inlet Temperature: 27 °C DB (80 °F DB)  
19 °C WB (66.2 °F WB)  
Outdoor Air Inlet Temperature: 35 °C DB (95 °F DB)

#### Heating Operation Conditions

Indoor Air Inlet Temperature: 20 °C DB (68 °F DB)  
Outdoor Air Inlet Temperature: 7 °C DB (45 °F DB)  
6 °C WB (43 °F WB)

Piping Length: 7.5 meters

Piping Lift: 0 Meter

2. The sound pressure is based on the following conditions.

1 Meter from the unit service cover surface, and 1.5 Meters from floor level.

The above data was measured in an anechoic chamber so that reflected sound should be taken into consideration in the field.

## Combination Table

Model	Utopia N HN(V)E			
	RAS-2.5HN(V)E	RAS-3HN(V)E	RAS-4HN(V)E	RAS-5HNE
<b>Single</b>	2.5	3.0	4.0	5.0
<b>Twin</b>	-	1.5/1.5	2.0/2.0	2.5/2.5 3.0/2.0

## Utopia Centrifugal Technical Description

- Non visible installation
- Highly reliable Hitachi scroll compressor
- Can be installed indoors
- Changeable configurations for air inlet and outlet

The Utopia Centrifugal units can be installed indoors with field supplied ductwork and are therefore ideal for situations where installations have to be hidden or where circumstances do not allow for the use of traditional styled outdoor units.

### Low temperature operation

Wide working range including Outdoor Unit Fan Control in cooling mode for operating at low ambient temperature as standard.

### Flexible Inlet Air and Outlet Air option

Four different configurations for Inlet and Outlet Air are available. Side panels and grilles could be changed in the field depending on each installation needs.

### Compatibility

Compatible with all Hitachi System Free indoor units.

### Utopia series control, H-Link connection

- H-LINK wiring system requires only two transmission wires connecting each indoor unit and outdoor unit for up to 16 refrigerant cycles, and connecting wires for all indoor units and all outdoor units in series.
- Total wiring length is remarkably reduced.
- Only one connection is required for the wiring between the indoor unit and outdoor unit.
- Easy wiring connection to the central controllers.

# Utopia Centrifugal



### Fan Performance Curves

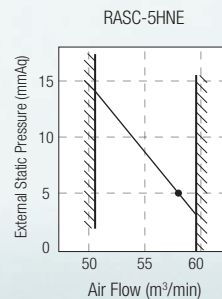

• : Normal point

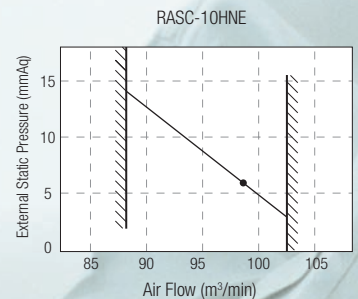

• : Normal point

## General Data

Model		RASC-5HNE	RASC-10HNE
<b>Electrical Power Supply</b>		3ø 400V 50Hz	
<b>Nominal Cooling Capacity</b> (Max/Nom/Min)	kW	12.50	25.00
<b>Nominal Heating Capacity</b> (Max/Nom/Min)	kW	14.00	28.00
<b>Cabinet Colour</b> (Munsell Code)	-	Soft Grey (9002)	
<b>Sound Pressure Level</b> (Night Shift)	dB (A)	53	60
<b>Outer Dimensions</b>			
Height	mm	555	640
Width	mm	1312	2050
Depth	mm	835	930
<b>Weight</b>	kg	175	310
<b>Refrigerant</b>	-	R410A	
<b>Flow Control</b>	-	Restrictor	
<b>Compressor</b>		Hermetic (scroll)	
<b>Quantity</b>		1	1
<b>Motor Output</b>	kW	3.75	(n.a)
<b>Heat Exchanger</b>		Multi-Pass Cross-Finned Tube	
<b>Fan Motor</b>		Centrifugal	
<b>Quantity</b>	-	1	1
<b>Air Flow Rate</b>	m³/min	58	98
<b>Nominal Static Pressure</b>	mmAq	50	63
<b>Motor Output(Pole)</b>	W	550	1100
<b>Refrigerant-Piping</b>		Flare-Nut Connection (Factory Supplied)	
Liquid Line	mm(in)	ø9.53 (3/8")	ø12.7 (1/2")
Gas Line	mm(in)	ø15.88 (5/8")	ø25.40 (1")
<b>Refrigerant Charge</b>	kg	4.8	8.5
<b>Maximum Current</b>	A	20	32
<b>Packing Measurement</b>	m³	0.60	1.22

### NOTES:

1. The nominal cooling and heating capacity is the combined capacity of the HITACHI standard split system, and are based on the ISO 5151..

#### Cooling Operation Conditions

Indoor Air Inlet Temperature: 27 °C DB (80 °F DB)  
19 °C WB (66.2 °F WB)

Outdoor Air Inlet Temperature: 35 °C DB (95 °F DB)

#### Heating Operation Conditions

Indoor Air Inlet Temperature: 20 °C DB (68 °F DB)

Outdoor Air Inlet Temperature: 7 °C DB (45 °F DB)  
6 °C WB (43 °F WB)

Piping Length: 7.5 meters

Piping Lift: 0 Meter

2. The sound pressure is based on the following conditions.

1 Meter from the unit service cover surface, and 1.5 Meters from floor level.

The above data was measured in an anechoic chamber so that reflected sound should be taken into consideration in the field.

## Combination Table

Model	RASC-5HNE	RASC-10HNE
<b>Single</b>	5.0	10.0
<b>Twin</b>	2.5/2.5 2.0/3.0	5.0/5.0 4.0/6.0
<b>Triple</b>	1.5/1.5/2.0	3.0/3.0/4.0
<b>Quad</b>	-	2.5/2.5/2.5/2.5

## Utopia – KPI Technical Description

### Structure

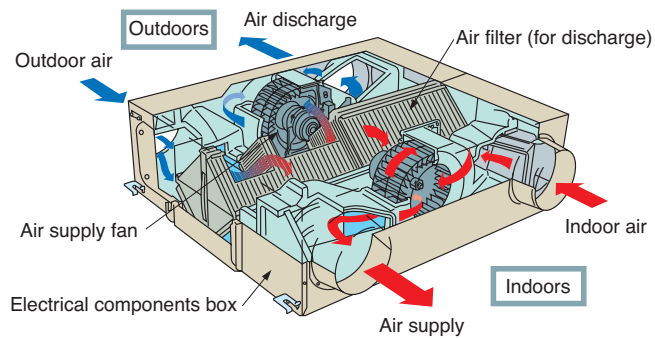

### Fixed Type Heat Exchanging Element

- The newly developed fixed type heat exchanging element with high temperature exchange efficiency equivalent to the rotor type element, has been adopted for the new total heat exchangers (Temp Exchange Efficiency: 77% <in case of 500m<sup>3</sup>/h type unit>). In addition, reliability is increased due to reduction of moving parts.
- Low weight with simple unit structure: 33kg (in case of 500m<sup>3</sup>/h type unit).

**Provides a comfortable environment by control interlocking with air conditioning units.**

**Controllable using the remote control switch for the air conditioning unit.**

Can be controlled in various ways using the remote control switch for the air conditioning unit (PC-P2HTE).

### Functions

- Simultaneous RUN/STOP switch both for air conditioning units and heat exchanging unit
- Individual operation of heat exchanging unit
- Fan speed control (high/medium/low)
- Ventilation mode selection (automatic/heat exchange/bypass)\*1
- Pre-cool/pre-heat control (interlocking start with delay in 30 or 60 minutes)\*1
- 7 day Time clock with PC-P2HTE
- Increased air supply operation
- Specific alarm display

\*1 Required option to be selected at remote control switch.

### Automatic selection of most suitable ventilation mode

Depending on temperature conditions both outdoors and indoors, the most suitable ventilation mode is automatically selected, designed for energy efficiency.

# Total heat exchanger

### Other Characteristics

- Quiet operation with low noise level of 32.5-33.5 dB (A) (at Hi Tap of KPI 5021 Type) has been realised by improving the flow path configuration.
- Operation not only with SET-FREE Series Indoor Unit, but also with UTOPIA Series Indoor Unit.
- Connectable to H-LINK System with Central Station or with CS-NET in Operation with Indoor Unit.
- Flexible Duct Installation: The connecting direction of duct at outdoor side (OA,EA) can be changed according to the condition of the installation site (2 directions).
- Reduced packing material for environment protection. The wood for the packing use has been reduced for environment protection.
- Can also be installed upside down.

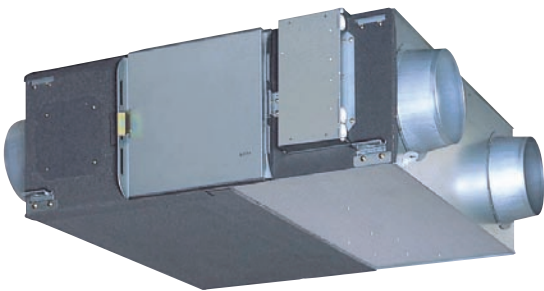

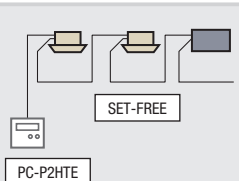
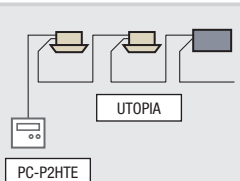
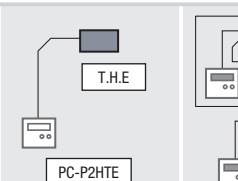
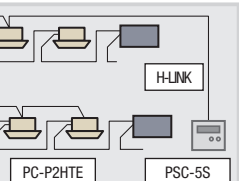

## General Data

	Standard Connection		Central Station (PSC-5S)	
Example System				
Configuration	Able to control up to 16 Indoor Units and Total Heat Exchanger Units		Direct Control	Able to control up to 128 Indoor Units consisting of 16 refrigeration cycles
Controllers	Remote Control Switch (PC-P2HTE)			<ul style="list-style-type: none"> <li>Central Station (PSC-5S)</li> <li>Remote Control Switch (PC-P2HTE)</li> </ul>

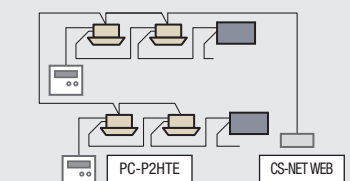
Hitachi Computer Control Network System CS-NET WEB	
Example System	
Configuration	Able to control up to 128 Indoor Units consisting of 16 refrigeration cycles
Controllers	<ul style="list-style-type: none"> <li>CS-NET WEB</li> <li>Remote Control Switch (PC-P2HTE)</li> </ul>

 INDOOR UNIT  
 TOTAL HEAT EXCHANGER (T.H.E.)

## General Data

	Model	KPI-2521	KPI-5021	KPI-8021	KPI-10021
<b>Power Supply</b>		AC 1Ø, 230V, 50 Hz			
<b>Air Flow Rate</b> (m³/min)	Hi	4.1	8.3	13.3	16.6
	Me	4.1	8.3	13.3	16.6
	Lo	2.75	5.8	11.1	14.5
<b>External Pressure</b> (mmAq)	Hi	6.5	15	14	16
	Me	4	6	10	10
	Lo	2	3	7	8
<b>Temperature Exchange Efficiency</b> (%)	Hi	78	77	78	79
	Me	78	77	78	79
	Lo	83	82	80.5	81
<b>Enthalpy Exchange Efficiency for Heating/Cooling</b> (%)	Hi	69/62.5	67/61.5	71/64.5	70/64.5
	Me	69/62.5	67/61.5	71/64.5	70/64.5
	Lo	74/68	73/68	73/68	73/67
<b>Sound Pressure Level</b> (Overall A Scale) at 1.5m from the unit (under)*3	Hi	26.5-27.5	32.5-33.5	33.5-34.5	36-37
	Me	25-26	30-31	32-33	34-35
	Lo	21-22	23.5-24.5	30-31	31.5-32.5
<b>Outer Dimensions</b>					
Height		275	317	398	398
Width		735	1016	1004	1231
Depth		780	888	1164	1164
<b>Net Weight</b>	Kg	21	33	61	72
<b>Approx Packing Measurement</b>	m³	0.26	0.46	0.70	0.84

### NOTES:

\*1 KPI-10021 has different units according to the applied power supply, 220-240v, 50Hz and 200V/60Hz

\*2 Use it under the following conditions. KPI-8021: 29Pa or more, KPI-10021: 49Pa or more

\*3 The sound pressure level is based on the following conditions; 1.5 meter beneath the unit and this data was measured in an anechoic chamber so that reflected sound should be taken into consideration in the field.

\*4 The sound pressure is based on the total heat exchange mode. In case of the bypass ventilation mode, the sound pressure level increased by approximately 1dB(A).

### H-Link Transmission System

This system connects the control wires for the outdoor and indoor units across two or more refrigerant systems. Regardless of the order or number of units to be connected, all the units can be controlled once they have been connected. By this method, design flexibility is very high, installation is easy and total costs are reduced. Furthermore, central control is possible by connecting CS-NET web to H-LINK wiring located in the room next to the room where CS-NET web is installed.

### Computer Controlled Network System



CS-NET web

# Control systems

### Computer System Network for the remote control and monitoring of air conditioning installation.

CS-NET web is a standalone central controller that can control up to 128 indoor units and up to 16 outdoor units connected to the Hitachi H-Link communication system. Using its Ethernet port, CS-NET Web connects to the Local Area Network or Internet (using a DSL router), allowing remote parameter setting and monitoring. CS-NET web client software is accessed directly through Internet Explorer and uses a Java application for remote control and monitoring. A useful feature is that two levels of access are available depending on the user type:

- 'User' access, allowing monitoring and setting of the unit
- 'Installer' access, allowing also Timer setting and change of system configuration



## Unit Setting

Different setting of the unit can be programmed remotely using CS-NET Web.

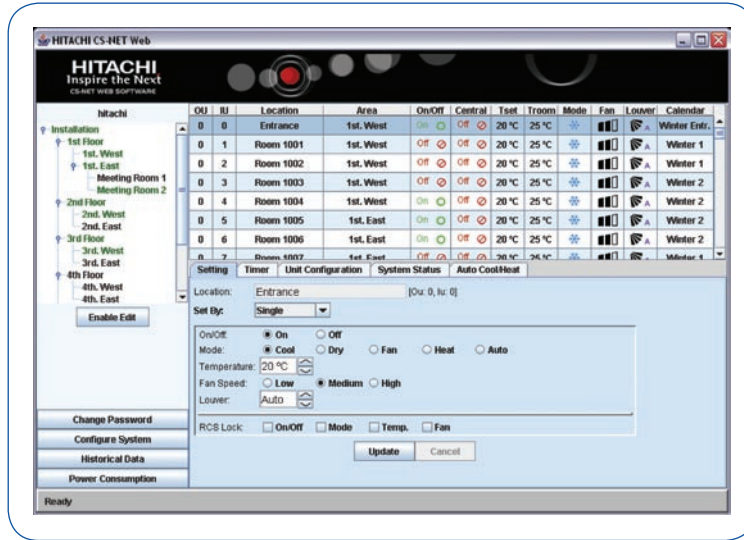

## Timer

4 year timer can be stored in the CS-NET Web remotely, allowing it to run standalone without a PC or manual operation.



## System Status and Historical Data

Different readings from the unit can be accessed remotely in order to give fast assistance for maintenance and monitoring of the system. These parameters are stored locally for several days to ease maintenance.

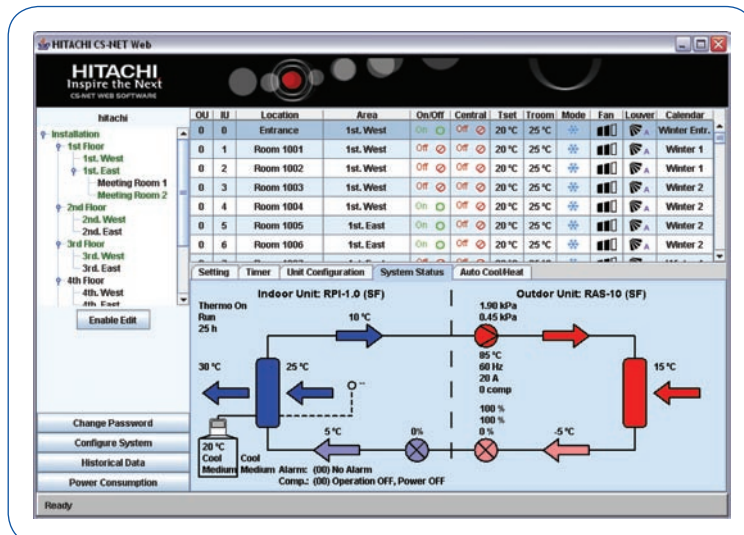

## Specifications of HARC-BX

Type	Standard		Option A		Option B	
<b>Connectable Q'ty</b>	64		64		32	
	Control	Monitor	Control	Monitor	Control	Monitor
<b>Run/Stop &amp; Alarm*</b>	•	•	•	•	•	•
<b>Operation Mode</b>	•	•	•		•	•
<b>Set Temp</b>	•	•	•		•	•
<b>Fan Speed</b>	–	–	•	–	•	•
<b>Louver Position</b>	–	–	–	–	•	•
<b>RC. Sw.Permission/Prohibition</b>	–	–	•	–	•	–
<b>Alarm Code</b>	–	–	–	–	–	•
<b>IU Inlet Air Temp</b>	–	–	–	•	–	•
<b>IU Outlet Air Temp</b>	–	–	–	–	–	•
<b>Outdoor Air Temp</b>	–	–	–	–	–	•
<b>Thermo-ON/OFF</b>	–	•	–	–	–	–
<b>Remark</b>	Use PC-P2HTE or PC-2H2					
<b>Maximum Wiring Length</b>	1000m (Bus Total length)					

\*Alarm for monitor only

# Lon Works® interface

## Gateway Interface to LON WORKS® BMS Systems

Using HARC-BX allows control of up to 5 setting points and remote monitoring of up to 9 valves. By connecting HARC-BX to H-LINK, a group of up to 16 remote controls can be used and up to 64 indoor units can be controlled.



HARC-BX



### PC-P2HTE/PC-ART

#### Remote Control Switch with Seven Day Timer

This remote controller can control up to 16 indoor units, has a large LCD display and an internal thermostat. It has a weekly timer function allowing four different schedules to be set over seven days. There is also a self diagnostic function and

all indoor unit functions including alarm codes can be accessed and displayed by this controller.

- Can control up to 16 indoor units
- Weekly timer function
- Full fault diagnostic facility
- Frost protection facility
- Energy Saving Option



### PC-LH3A

#### Wireless Remote Control Switch

A wireless remote control switch that provides simple one-touch operation and can control two or more units simultaneously. No wiring work is required and the receiver kit is integral in wall mounted units. A receiver kit PC-RLH11 is required for all other models.

- Wireless Remote Control
- For use in place of hard wired PC-P2HTE
- Receiver PC RLH4 required with CS Net and central station.



### PC-P5H1/PC-ARH

#### Simplified Remote Control Switch

Smaller than the conventional remote controller the main function is temperature adjustment. It is ideal for a variety of applications such as hotels, restaurants and offices because it is easy to use. It can control a maximum of 16 indoor units similar to the standard

hard wired controller and displays alarm codes on a simple LED panel.

- Simple and easy to use
- On/off temperature and fan speed control
- Limited range of diagnostic functions

# Remote controllers



### PSC-5S/PSC-A64S

#### Centralised Remote Control Switch

The Central Station enables centralised control of up to 16 groups of indoor units (256 units in total). It features a wide range of functions, including a large liquid crystal display screen remote start/stop and alarm code display.

- Simple control for large installations
- Max of 256 units
- Remote control grouping



### PSC-5T/PSC-A1T

#### 7-Day Timer

The 7-Day Timer allows long-term unattended control. By connecting this timer to the optional remote control switch or central station daily ON/OFF operation control throughout the week is available. The ON/OFF setting is available three times a day in two different patterns.

- Two types of weekly schedule (A and B) can be set, and can easily be changed for summer and winter operation
- Settings are all digitally displayed, allowing operations and settings to be easily checked

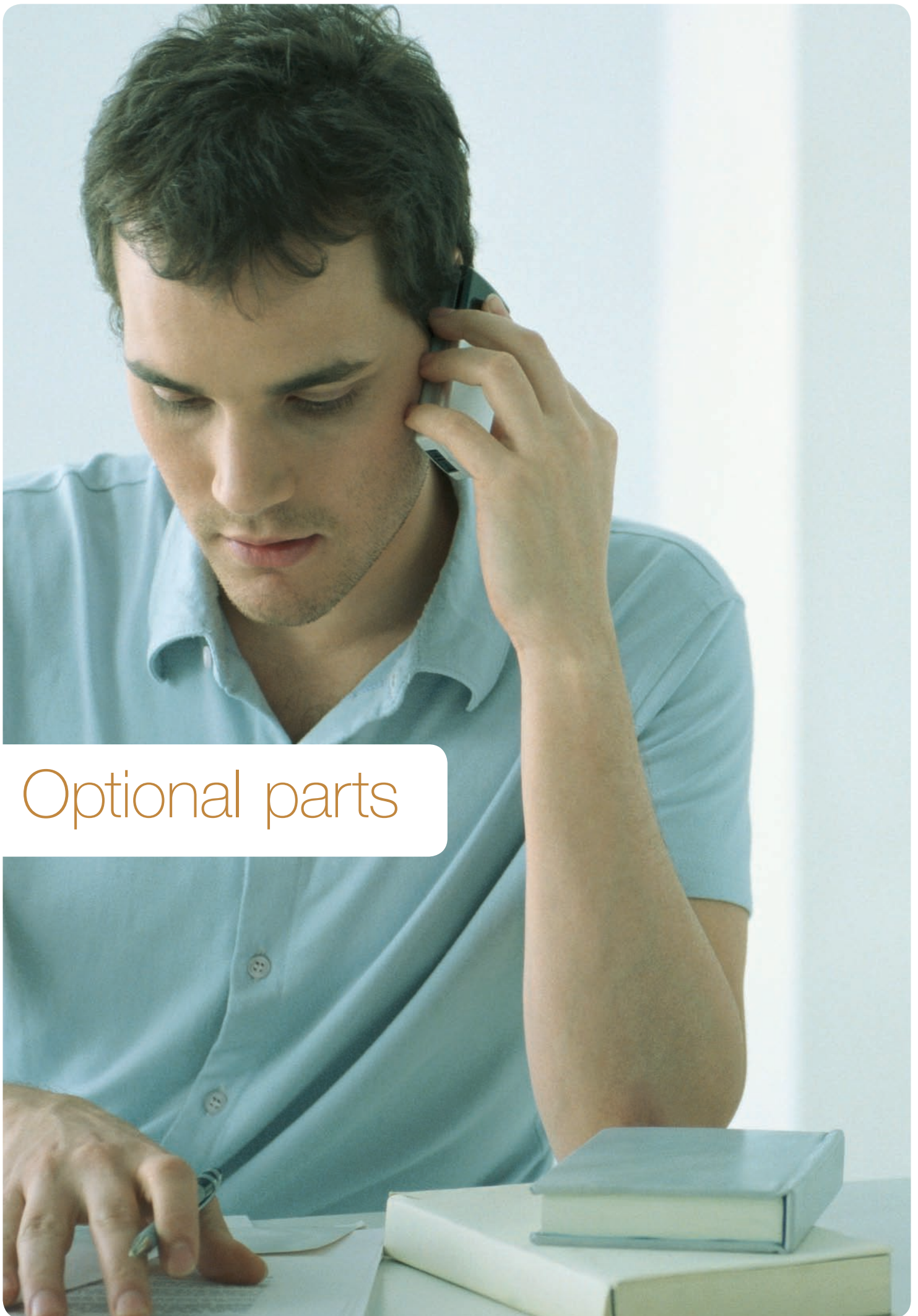

Optional parts

## Indoor Units

### 4-Way Cassette Type

Item	RCI-1.0-6.0	RCIM-1.5-2.0
Receiver Kit for Wireless Control	PC-RLH8/PC-ALH (on the panel)	PC-RLH13/PC-ALHC (on the panel)

### 2-Way Cassette Type

Item	RCD 1.0-5.0
Receiver Kit for Wireless Control	PC-RLH9/PC-ALHD (on the panel)

### Wall Mounted and Mini Wall Mounted

Item	RPK 0.8-4.0
Wireless Receiver Kit	As standard

### In-the-Ceiling, Wall, Floor and Ceiling Type

Item	RPI (0.8-5.0HP), RPK (0.8-4.0HP), RPC (2.0-5.0HP), RPF (1.0-2.5HP), RPI (1.0-2.5HP)
Receiver Kit for Wireless Control (with 5m cable)	PC-RLH11/PCALHC (wall mounted)

### In-the-Ceiling, Wall, Floor and Ceiling Type

Item		RPI-FSN	RCI-FSN	RCD-FSN	RPK-FSN	RPC-FSN	RPF(I)-FSN	KPI
Remote Control Switch*1	PC-P2HTE/PC-ART (without cable)	•	•	•	•	•	•	•
Wireless Remote Control Switch*2	PC-LH3A	•	•	•	•	•	•	•
Half-size Remote Control Switch	PCP-5H1/PC-ARH	•	•	•	•	•	•	•
7-Day Timer	PSC-5T/PSC-A1T	•	•	•	•	•	•	•
Centralised Remote Control Switch*3	PSC-5S/PSC-A645	•	•	•	•	•	•	•
3P Connector Cable	PCC-1A	•	•	•	•	•	•	•
Remote Sensor	THM-R2A	•	•	•	–	•	•	–
Computer Controlled Network System	CS-NET	•	•	•	•	•	•	•

\*1 As the PC-P2HTE does not include a remote control cable, prepare one in the field, or use PRC-10E1, 15E1, 20E1, 30E1.

\*2 PC-LH3 can be used instead of PC-LH3A.

\*3 Supply 220V or 240V

## Outdoor Units

Item	RAS-2/2.5	RAS-3-12
Drain Discharge Boss	DBS-12L	DBS-26
Branch Pipekit	TE-03/04/56/08/10N, TRE-06/810N, RE-810N	





Specifications in this catalogue are subject to change without notice in order that HITACHI may bring the latest innovations to their customers, omitting typing errors.

Hitachi Europe Ltd  
Whitebrook Park  
Lower Cookham Road  
Maidenhead  
Berkshire  
SL6 8YA  
United Kingdom

tel: 01628 585394

email: [aircon.enquiries@hitachi-eu.com](mailto:aircon.enquiries@hitachi-eu.com)

[www.hitachiaircon.com](http://www.hitachiaircon.com)

HELGB UTP 003

Distributed by:



**HITACHI**  
Inspire the Next