

**FUJITSU**

THE POSSIBILITIES ARE INFINITE

SPLIT & WINDOW TYPE  
AIR CONDITIONERS



**THE INTELLIGENT CHOICE IN COMFORT**

**FUJITSU GENERAL LIMITED**

# Energy saving & Ecology

Deepening environmental, resources and global warming problems. As a global enterprise, Fujitsu General group recognizes that contributing to development of a sustainable economic society is today's most important management topic, and is engaged in a series of environmental protection activities reaching up to sales, maintenance, and recycling, and is aggressively making its products more energy saving.

# CLASS A CLASS A

## Energy-Efficiency Classifications

According to a new EC Directive, the indication of the Energy Efficiency classification on household air conditioners became compulsory. This aims to provide consumers with clear and objective information regarding energy-saving, and to encourage them to select products that are environmentally friendly. An Energy Label, like that shown in the sample below, will be provided in shop displays. In the label, the equipment is rated, with "A" being the most efficient. You may notice these labels and ratings appearing soon in shops that sell air conditioners. For easy understanding, the following information will be indicated for each model.

**Energy Label**

**The product**  
Air-conditioner  
FUJITSU  
AO-\*\*\*  
AS-\*\*\*

**The model number**

**The class**  
An energy efficiency class in seven steps, from A to G.

**Annual energy consumption**  
The annual energy consumption is calculated by multiplying the total power input by an average of 500 hours per year in cooling mode at full load.

**The Energy Efficiency Ratio**  
The higher the EER, the greater the energy efficiency.

**The type of air conditioner**

**The noise**

Outdoor  
Indoor

Further information is contained in product brochures

Norm EN 814  
#MicroBuster  
Energy Label Directive 2002/91/EC

## Classifications

There are seven classifications of energy efficiency, from A to G. The most efficient level is "A" and the least efficient level is "G".

Energy efficiency class of the unit in COOLING mode	Energy efficiency class of the unit in HEATING mode
<b>A</b> 3.20 < EER	<b>A</b> 3.60 < COP
<b>B</b> 3.20 ≥ EER > 3.00	<b>B</b> 3.60 ≥ COP > 3.40
<b>C</b> 3.00 ≥ EER > 2.80	<b>C</b> 3.40 ≥ COP > 3.20
<b>D</b> 2.80 ≥ EER > 2.60	<b>D</b> 3.20 ≥ COP > 2.80
<b>E</b> 2.60 ≥ EER > 2.40	<b>E</b> 2.80 ≥ COP > 2.60
<b>F</b> 2.40 ≥ EER > 2.20	<b>F</b> 2.60 ≥ COP > 2.40
<b>G</b> 2.20 ≥ EER	<b>G</b> 2.40 ≥ COP

These classifications are for split and multi-split air conditioners.

# ALL DC ALL DC

## ALL DC saves energy throughout the year

**DC Fan Motor**

**Inverter Control Base**



**DC Fan Motor**

























**DC Compressor**



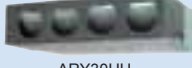
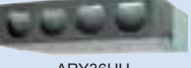
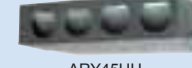

By making all the motors DC, electricity loss is decreased and power consumption is substantially reduced. In addition, fan motor high speed rotation is possible, and heat exchange efficiency is increased and annual power consumption amount is saved by increasing the airflow.

# SPLIT & WINDOW TYPE AIR CONDITIONERS LINEUP

Single Split & Window						
Model/ Capacity class	2.0kW	2.6kW	3.5kW	4.1kW	5.3kW	7.1kW
<b>INVERTER</b> Ceiling wall (noctria) <b>P.6</b>				 AWYZ14LB	 AWYZ18LB	 AWYZ24LB
<b>INVERTER</b> Wall mounted (Plasma) <b>P.8</b>		 ASYB09LD	 ASYB12LD		 ASYB18LD	 ASYB24LD
<b>INVERTER</b> Wall mounted (Compact) <b>P.10</b>	 ASYA07LG	 ASYA09LG	 ASYA12LG	 ASYA14LG		
<b>INVERTER</b> Wall mounted (Large) <b>P.12</b>					 ASYA18LE	 ASYA24LC
Wall mounted <b>P.13</b>	 ASY7UB	 ASY9UC	 ASY12UC	 ASY14UB	 ASY18UB	 ASY24UB
<b>INVERTER</b> Floor <b>P.14</b>		 AGYF09LA	 AGYF12LA	 AGYF14LA		
<b>INVERTER</b> Cassette <b>P.20</b>			 AUYF12LA	 AUYF14LA	 AUYF18LA	 AUYA24LB
<b>INVERTER</b> Floor/Ceiling <b>P.25</b>					 ABYF18LA	 ABYF24LA
<b>INVERTER</b> Duct <b>P.27</b>			 ARYF12LA	 ARYF14LA	 ARYF18LA	 ARYA24LA
<b>INVERTER</b> Duct (High static pressure) <b>P.29</b>						
Cassette <b>P.30</b>			 AUY12UB	 AUY14UB	 AUY18UB	 AUY25UU
Floor/Ceiling <b>P.32</b>				 ABY14UB	 ABY18UB	 ABY24UB
Duct <b>P.34</b>	 ARY7UU	 ARY9UU	 ARY12UU	 ARY14UU	 ARY18UU	 ARY25UU
Window <b>P.40</b>		 AKY9UB	 AMY12UA	 AFY16UA		

Multi Split <b>INVERTER</b> <b>P.16</b>					
Indoor	Wall mounted	Wall mounted	Floor	Compact Cassette	Compact Duct
	 ASWA07LA ASWA09LA ASWA12LA ASWA14LA ASWA18LA	 ASW24LB	 AGYF09LA AGYF12LA AGYF14LA	 AUYF09LA AUYF12LA AUYF14LA AUYF18LA	 ARYF09LA

8.8kW	10.6kW	13.2kW	15.8kW	17.6kW	26.4kW					
										
						 ASYS30LC				
						 ASYS30UB				
 AUYA30LB	 AUYA36LB	 AUYA45LA	 AUY54LU							
 ABYA30LB	 ABYA36LB	 ABYA45LA								
 ARYA30LB	 ARYA36LB	 ARYA45LA								
		 ARY45LH	 ARY54LU							
 AUY30UU	 AUY36UU	 AUY45UU	 AUY54UU							
 ABY30UB	 ABY36UB	 ABY45UB	 ABY54UB							
 ARY30UU	 ARY36UU	 ARY45UU		 ARY60UU	 ARY90TL					

Compact Duct	Floor/Ceiling Universal	Outdoor	2 rooms	3 rooms	4 rooms
 ARYF12LA ARYF14LA ARYF18LA ARYF22LA	 ABYF14LA ABYF18LA ABYF24LA		 AOY18LMAK2 AOY24LMAM2	 AOYA18LAT3 AOYA24LAT3	 AOY30LMAW4

## CEILING WALL TYPE

**nocria®**



5th year of record achievements. Automatic filter cleaning air conditioner



For AWYZ14/18LB



For AWYZ24LB

CLASS **A** ALL **DC**  
AWYZ14LB

CLASS **A** ALL **DC**  
AWYZ18LB

CLASS **A** ALL **DC**  
AWYZ24LB

### Automatic filter cleaner **WORLD FIRST**\*1

**Entire filter is cleaned automatically in approx. 2 minutes**

Since the filter is cleaned automatically, energy saving capability is displayed without regard to the load on the air conditioner.

**Energy saving CLASS A cleared with a margin to spare**

If the energy saving effect is maintained, filter cleaning once every 2 weeks is effective.

**2 exhaustive bacteria eliminating and deodorizing countermeasures keep the air in the room clean**

If the energy saving effect is maintained, filter cleaning once every 2 weeks is effective.

### Bacteria eliminating countermeasure

- a** Dirt and dust are bacteria-eliminated by photocatalytic filter\*  
\* Displays double the effect of a conventional optical medium and retains its property for a long time to suck in and remove approx. 99.99% of cigarette odors and bacteria, etc.
- b** Drives away bacteria and refreshes the air by UV (ultraviolet rays) illumination

### Our unique technology that achieved top energy efficiency in the industry

- c** Energy saving by automatic filter cleaning function\*1  
This function allows an energy saving of more than 25% a year and maintains a smooth airflow by preventing the filters from being clogged with dust.
- d** Computer-designed fan provides a larger airflow than conventional models  
New air trunk, which provides a smooth airflow, and axial gap fan motor increase the max. airflow by 10% over that of conventional models.



CAE analysis

- e** Axial gap fan motor enables nonconventional high power and high efficiency\*2

#### Axial gap method

Rotor plates are installed above and below electromagnets.

#### Features (Compared to conventional models)

Compact size with 1.5 more power output Self-driven method increases rotating efficiency by 10%. Our electromagnetic field simulation technology enables low vibration and low noise.

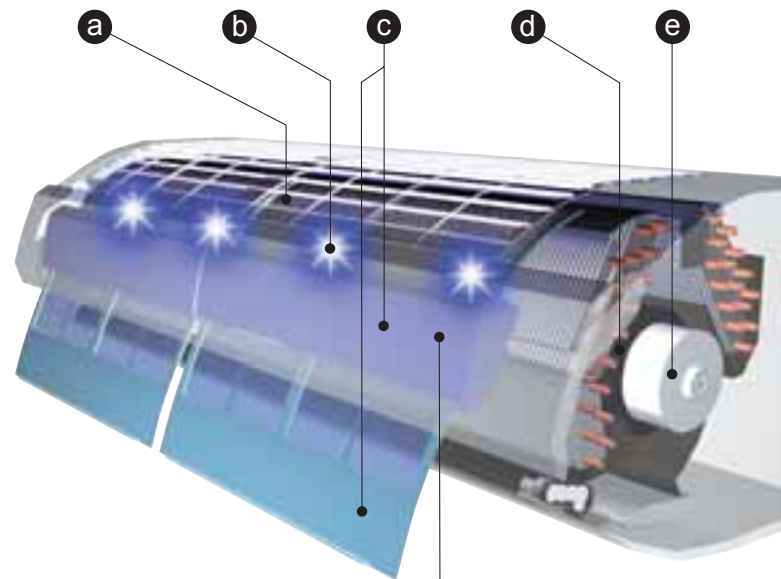
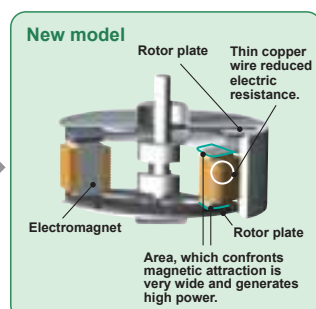
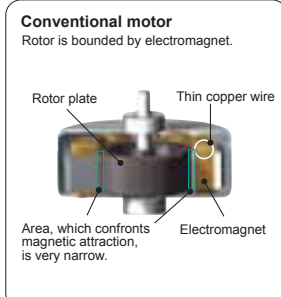

#### Antibacterial dust box

Removes dirt and dust by double brushes. Dust collection is approx. twice that in the past. (our company's comparison) Maintenance: Only throwing into a trash bin once every 2 years

\*1: Announced September 9, 2002. In room air conditioner for the home (Our company's investigation)  
\*2: Announced December 13, 2004. As fan motor for air conditioner (Our company's investigation)

## V-PAM inverter increases the max. output of the compressor significantly & enables high power & high efficiency

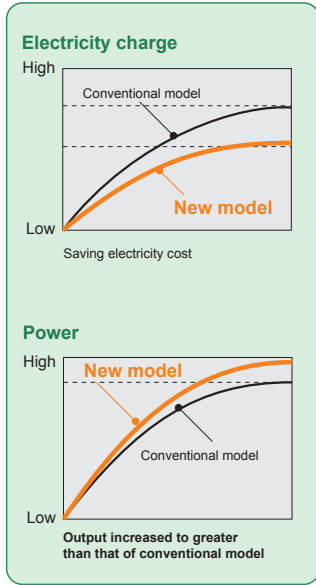
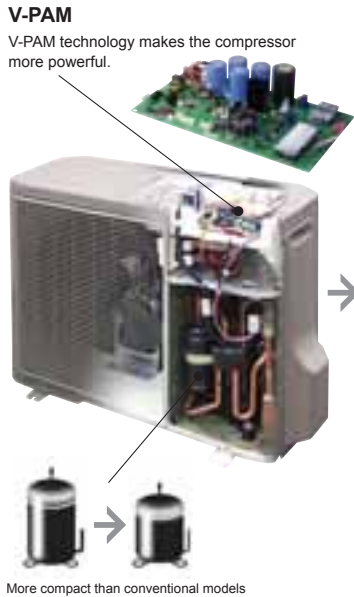

Comparison between V-PAM and conventional PAM

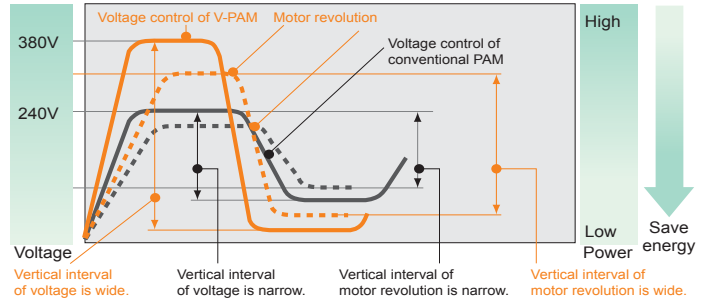

**Conventional PAM**  
Control range between energy saving and high power is small because vertical interval of voltage and motor revolution is narrow.

**V-PAM**  
V-PAM achieves high power by increasing the voltage up to 380V and making the motor rotate faster, and also saves energy in the stable state by making the motor rotate slower than that of conventional models by lowering the voltage.

## "Vertical airflow" provides powerful floor level heating

**No.1 Heating capacity**

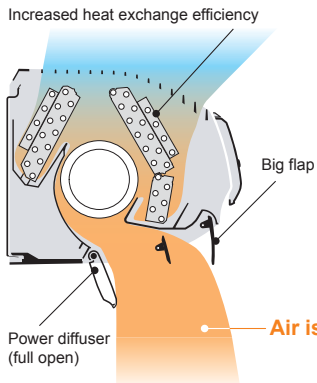

## "Horizontal airflow" does not blow cool air directly at the occupants in the room

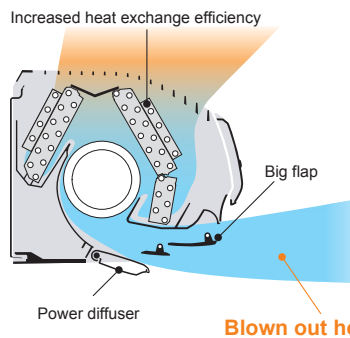

### SPECIFICATIONS

Reference	Model No.	Indoor Unit		AWY14LB	AWY18LB	AWY24LB
		Outdoor Unit		AOY14LB	AOY18LB	AOY24LB
Input Power		V/ø/Hz	230/1/50	230/1/50	230/1/50	230/1/50
Capacity	Cooling	kW	4.20 (0.9~5.3)	5.20(0.9~5.9)	7.10(0.9~8.0)	
			6.00 (0.9~9.1)	6.70 (0.9~9.7)	8.50(0.9~11.0)	
Power Consumption	Cooling/Heating	kW	1.02/1.35	1.58/1.63	2.21/2.24	
		EER - Energy Class	Cooling	4.12-A	3.29-A	3.21-A
COP - Energy Class	Heating	W/W	4.44-A	4.11-A	3.62-A	
		Running Current	Cooling/Heating	A	4.5/5.9	6.9/7.2
Moisture Removal		l/h	2.1	2.8	3.0	
Noise (Indoor)	Cooling/H/M/L/Q/SQ	dB(A)	46/43/35/29/24			47/43/40/36/32
Noise (Outdoor)	Cooling		46			53
Airflow (High)	Indoor/Outdoor	m³/h	850/1910		880/3600	
		mm	250x899x298		250x899x298	
Net Dimension H x W x D	Indoor	kg(lbs)	13.5(30)		14(31)	
		mm	578x790x300		830x900x330	
Weight	Outdoor	kg(lbs)	39(86)		62(137)	
		mm	6.35/12.70		6.35/15.88	
Piping Connections(Small/Large)			16/29		16/29	
Drain Pipe Diameter (Inner/Outer)			20(15)		30(15)	
Max Pipe Length (Chargeless)		m	15		20	
Max Height Difference	Cooling	°C	-10~43		-10~43	
			-15~24		-15~24	
Operation Range	Heating	-10~43		-10~43		
		-15~24		-15~24		
Refrigerant			R410A	R410A	R410A	

# INVERTER

# WALL MOUNTED TYPE

**PLASMA AIR CONDITIONER**

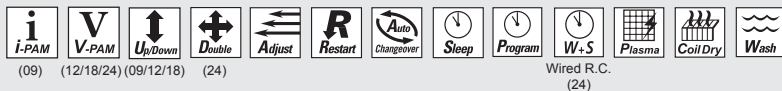

ASYSB09/12/18LD



ASYSB24LD



Wireless R.C. (09/12/18)



Wireless R.C. (24)

CLASS A ALL DC

ASYSB09LD

CLASS A ALL DC

ASYSB12LD

CLASS A ALL DC Heating

ASYSB18LD

CLASS A ALL DC

ASYSB24LD

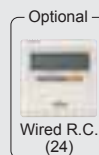

Wired R.C. (24)



For ASYSB09/12LD



For ASYSB18/24LD

## Original plasma air cleaning unit effectively cleans the air in the room

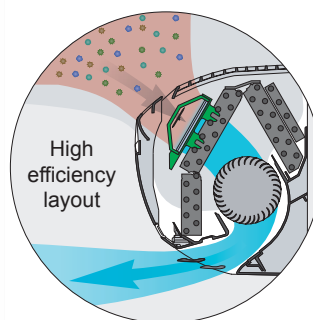

Plasma air filter mechanism



### Plasma unit

Mounts a plasma air cleaning unit. Minute dust particles are collected by an electrostatic filter and odor is suppressed by decomposition of foul odors by very weak ions. Since a filter with a lower ventilation resistance than in the past is used, high dust collection design simultaneously cleans the air in the room.

Negatively-charged dust, etc. are attracted to the earth section and are collected by a bacteria eliminating and deodorizing filter.

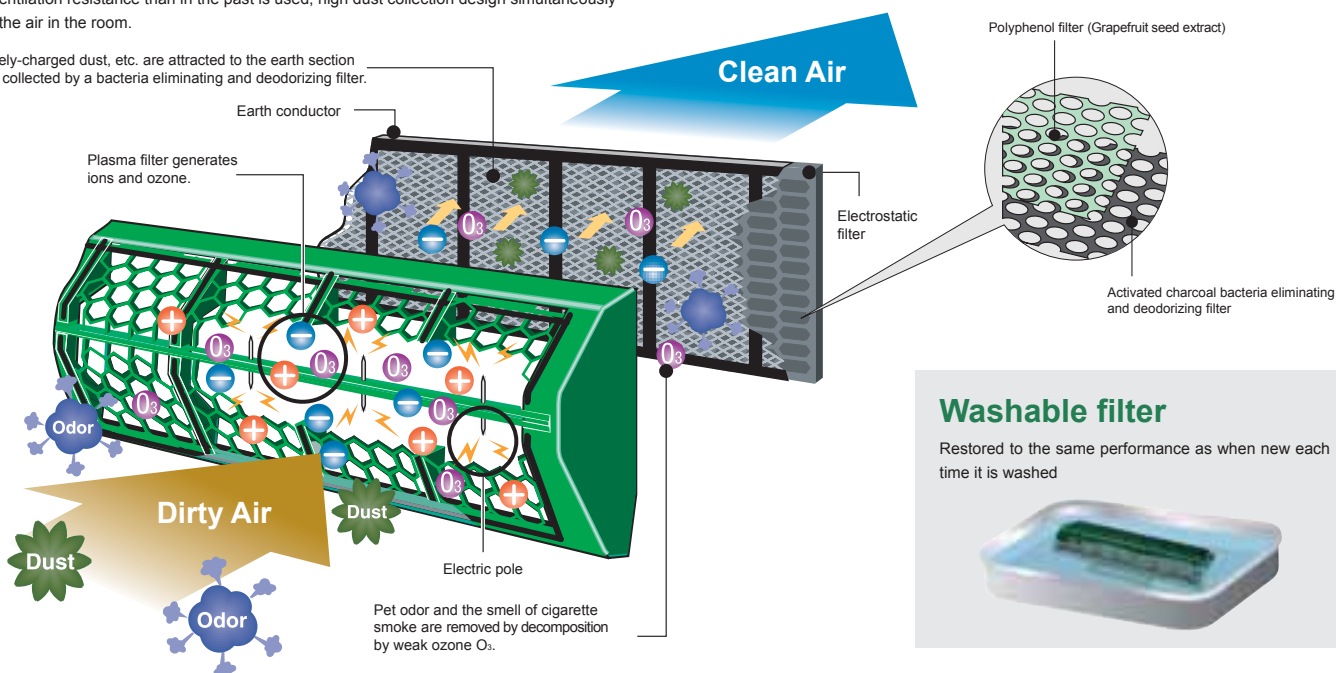

### Washable filter

Restored to the same performance as when new each time it is washed

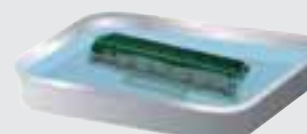



## Plasma air cleaner quickly removes small dust particles & odors

### Collects dirt such as...

House dust / Pet fur and dander / Cigarette smoke / Mite carcass / Mold spore / Pollen

### Absorbs odors such as...

Smell of cigarette smoke / Pet odor / Kitchen garbage smell / Perspiration and body odor

#### Dust collection performance (ASYB09/12/18LD)

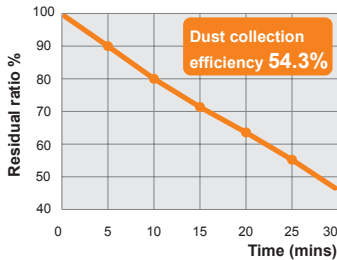

Test method: JEM 1417  
Test room: 30m<sup>3</sup>, sealed room  
Measurement conditions: Cigarette smoke (5 cigarettes burned simultaneously)

#### Deodorizing performance (ASYB09/12/18LD)

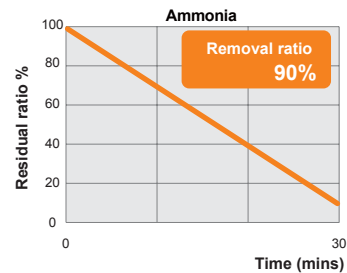
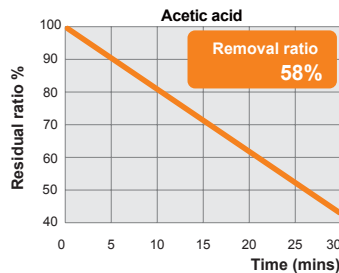

Test method: JEM1467  
Test room: 1m<sup>3</sup>, acrylic sealed box  
Measurement method: Cigarette smoke (5 cigarettes burned simultaneously)

#### Bacteria elimination effect by Polyphenol ceraglaze

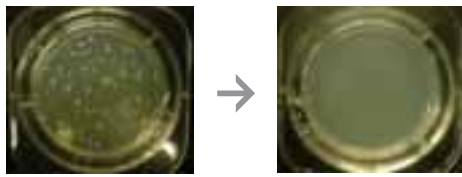

The undiluted solution of the specimen was made the specimen fluid and suspensoid 0.1ml (approx. 107CFU/ml) of the test bacteria was inoculated.

Tested by KITAZATO environment science center  
Test NO. :15-0253 Test condition: at 20 degrees C/24 hour action

## Inner drying operation & plasma effect

This model is equipped with an inner drying function. After the power is turned off, the dry operation starts inside the air conditioner. The plasma air cleaning unit eliminates bacteria, deodorizes, and keeps the interior of the air conditioner clean by generating ozone and ions.

#### Covered with beading

Bacteria grows in beading, and it causes bad odor.

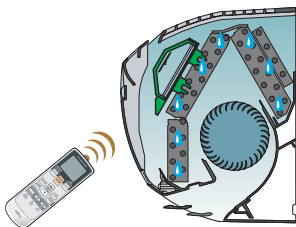

After operation ends, start approx. 30 minutes speed cleaning operation by merely pressing the COIL DRY button.

#### Removes moisture

Drying operation for approx. 15 mins



#### Bacteria elimination

Ozone bacteria eliminating operation for approx. 15 mins

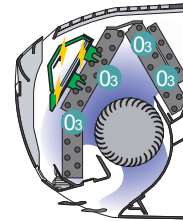

"Inner drying operation" and "ozone bacteria eliminating operation" keep the inside of the air conditioner clean at all times. That's why air from the air conditioner is always clean and high efficiency is realized.

## Easy maintenance

### Easy maintenance and always clean. Troublesome maintenance has been made easy.

Since the front panel is easy to remove, maintenance is also easy.

#### Open panel



ASYB09/12/18LD

## Low ambient

High efficiency compressor and newly added sensor for monitoring the refrigerant temperature makes possible fine-tuned inverter control which, in turns, make it possible to correspond to lower outdoor temperatures.

Cooling	Heating
<b>-10 to 43°C</b>	<b>-15 to 24°C</b>

#### SPECIFICATIONS

Reference	Model No.	Indoor Unit		ASYB09LD	ASYB12LD	ASYB18LD	ASYB24LD	
		Outdoor Unit		AOYS09LD	AOYS12LD	AOYS18LD	AOYS24LD	
Input Power			V/ø/Hz	230/1/50	230/1/50	230/1/50	230/1/50	
Capacity		Cooling	kW	2.60(0.5~3.7)	3.50(0.9~4.3)	5.20 (0.9~5.7)	7.10(0.9~8.0)	
				Heating	3.60(0.5~6.1)	4.80(0.9~6.7)	6.25 (0.9~9.1)	8.10(0.9~10.6)
Power Consumption		Cooling/Heating	kW	0.61/0.81	0.91/1.22	1.72/1.73	2.21/2.24	
EER - Energy Class		Cooling	W/W	4.26-A	3.85-A	3.02-B	3.21-A	
COP - Energy Class		Heating		4.44-A	3.93-A	3.61-A	3.62-A	
Running Current		Cooling/Heating	A	2.9/3.9	4.3/5.5	7.6/7.7	9.7/9.8	
Moisture Removal			l/h	1.3	1.8	2.8	3.0	
Noise (Indoor)		Cooling	H/M/L/Q	dB(A)	39/34/29/20	41/35/29/20	45/39/33/26	49/43/38/33
Noise (Outdoor)		Cooling		dB(A)	47	47	50	52
Airflow (High)		Indoor/Outdoor	m <sup>3</sup> /h	560/1970	595/1830	700/2000	1170/2340	
Net Dimension H x W x D	Indoor		mm	283x790x230	283x790x230	283x790x230	320x998x228	
				kg(lbs)	9.5(21)	9.5(21)	10(22)	14(31)
Weight	Outdoor		mm	540x790x290	540x790x290	578x790x300	578x790x315	
				kg(lbs)	34(75)	36(80)	40(88)	44(97)
Piping Connections(Small/Large)			mm	6.35/9.52	6.35/9.52	6.35/12.7	6.35/15.88	
Drain Pipe Diameter (Inner/Outer)			mm	16/29	16/29	16/29	16/29	
Max Pipe Length (Chargeless)			m	20(15)	20(15)	20(15)	30(15)	
Max Height Difference			m	15	15	15	20	
Operation Range		Cooling	°C	-10~43	-10~43	-10~43	-10~43	
		Heating	°C	-15~24	-15~24	-15~24	-15~24	
Refrigerant				R410A	R410A	R410A	R410A	

## WALL MOUNTED TYPE

Simple & Elegant Appearance Design  
Ensuring Compatibility with Compact Energy Saving



For ASYA07/09/12LG



For ASYA14LG



CLASS **A** ALL **DC**  
ASYA07LG

CLASS **A** ALL **DC**  
ASYA09LG

CLASS **A** ALL **DC**  
ASYA12LG

CLASS **A** ALL **DC**  
ASYA14LG

### Compact Sized Indoor Unit

Top class compact size achieved by realizing the highest efficiency in the industry

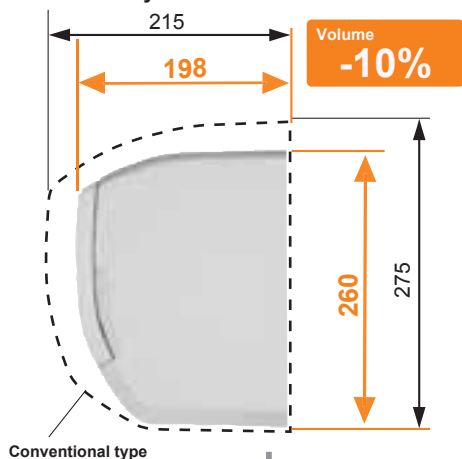

Simple and compact design matches any interior decor



### High density heat transfer tube arrangement realized by making the tube thin

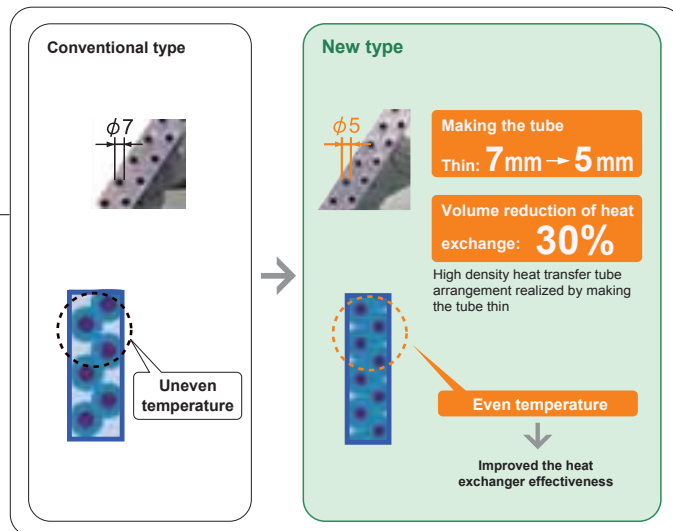

### Compact Sized Outdoor Unit

Top class compact size increases workability and installation flexibility

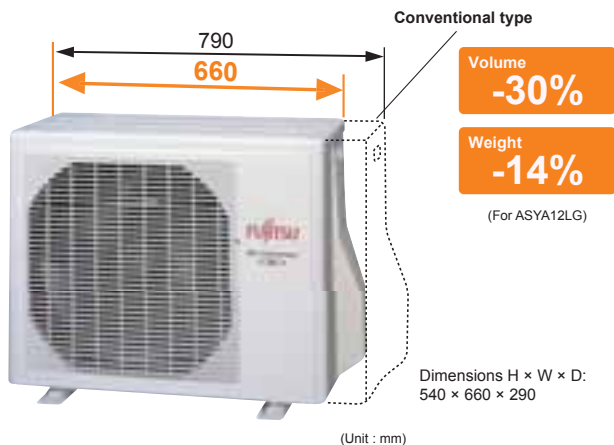

Compact design allows a wider selection of outdoor unit installation sites

### 10°C HEAT Operation

The room temperature can be set to go no lower than 10°C, thus ensuring that the room does not get too cold when not occupied

Caution)

- When the room temperature is higher than 10°C, "10°C HEAT" operation does not start. Operation starts and maintains the room temperature at 10°C for 48 hours when the temperature drops below 10°C.
- When "10°C HEAT" operation stops, the room set temperature quickly returns to the preset temperature.

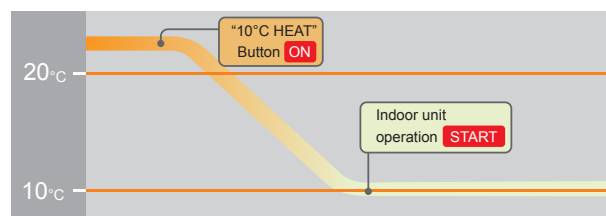

## Air conditioner filter features





**Long-life\*  
Ion Deodorization Filter**

The filter deodorizes by powerfully decomposing absorbed odors using the oxidizing and reducing effects of ions generated by the ultra-fine-particle ceramic.

(\*The filter can be used for approx. 3 years if it is washed under water to restore its surface action when it is dirty.)

+ Using different filters at both sides



**Apple-catechin Filter**

Fine dust, invisible mold spores, and harmful microorganisms are absorbed onto the filter by static electricity, and further growth is inhibited and deactivated by the polyphenol extracted from apples.

### Deodorizing effect (Odor reduction rate)

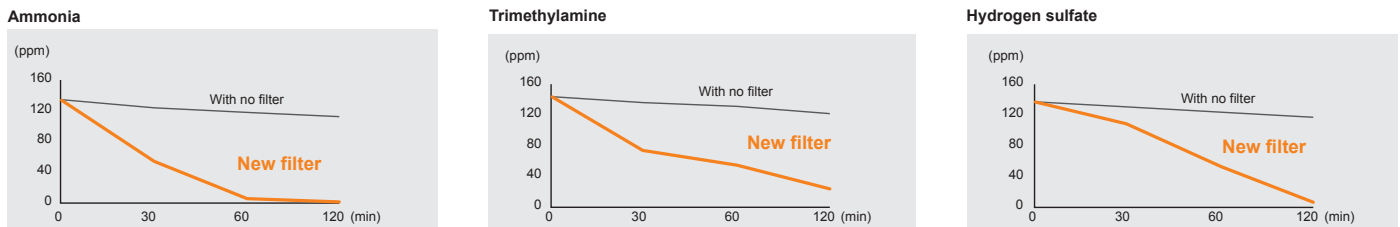

Testing organization : Environmental Sanitary Inspection Center Test method : Deodorization Test

## Easy maintenance

**Easy maintenance and always clean.  
Troublesome maintenance has been made easy.**

Since the front panel is easy to remove, maintenance is also easy.



## Quiet operation

Cooling mode

Fan speed	Noise level
Quiet	21dB(A)

(07/09/12TYPE)

## Low ambient

High efficiency compressor and newly added sensor for monitoring the refrigerant temperature makes possible fine-tuned inverter control which, in turns, make it possible to correspond to lower outdoor temperatures.

Cooling	Heating
-10 to 43°C	-15 to 24°C

## Inner drying operation

During dew condensation



Approx. 50 mins Drying

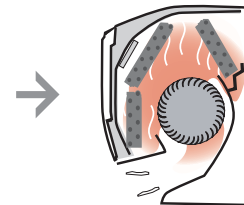

This model is equipped with an inner drying function. After the power is turned off, the dry operation starts inside the air conditioner.

This prevents the growth of mold and bacteria inside the air conditioner.

## SPECIFICATIONS

Model No.	TENTATIVE		TENTATIVE	
	Indoor Unit	Outdoor Unit	Indoor Unit	Outdoor Unit
Reference	AS YA07LG	AOYR07LG	AS YA09LG	AOYR09LG
Reference	AS YA12LG	AOYR12LG	AS YA14LG	AOYR14LG
Input Power	V/ø/Hz	230/1/50	230/1/50	230/1/50
Capacity	Cooling	kW	2.1	2.50(0.5~3.2)
	Heating	kW	3	3.20(0.5~4.5)
Power Consumption	Cooling/Heating	kW	0.47/0.66	0.63/0.75
EER - Energy Class	Cooling	W/W	4.47-A	3.97-A
COP - Energy Class	Heating	W/W	4.55-A	4.27-A
Running Current	Cooling/Heating	A	- / -	3.2/3.7
Moisture Removal		l/h	-	1.3
Noise (Indoor)	Cooling   H/M/L/Q	dB(A)	42/ - / - /21	43/39/33/21
Noise (Outdoor)	Cooling	dB(A)	47	45
Airflow (High)	Indoor/Outdoor	m <sup>3</sup> /h	- / -	750/1720
Net Dimension H x W x D	Indoor	mm	260x790x198	260x790x198
	Outdoor	mm	540x660x290	540x660x290
Weight	Indoor	kg(lbs)	7.5(17)	7.5(17)
	Outdoor	kg(lbs)	25(55)	32(71)
Piping Connections(Small/Large)		mm	6.35/9.52	6.35/9.52
Drain Pipe Diameter (Inner/Outer)		mm	16/29	16/29
Max Pipe Length (Chargeless)		m	20(15)	20(15)
Max Height Difference		m	15	15
Operation Range	Cooling	°C	-10~43	-10~43
	Heating	°C	-15~24	-15~24
Refrigerant			R410A	R410A

# INVERTER

# WALL MOUNTED TYPE

Simple & Elegant Appearance Design

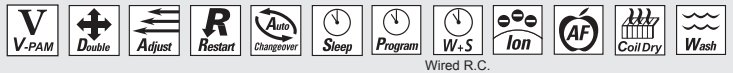

Wireless R.C. | Optional Wired R.C. | For ASYA18LE | For ASYA24LC | For ASYA30LC

**CLASS A ALL DC** ASYA18LE **NEW**

**CLASS A ALL DC** ASYA24LC

**ALL DC** ASYA30LC

## Power diffuser

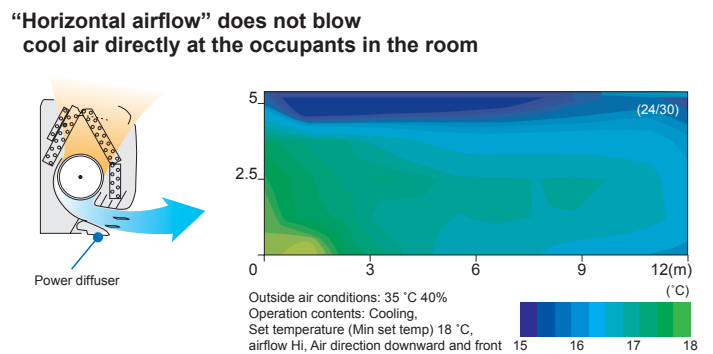
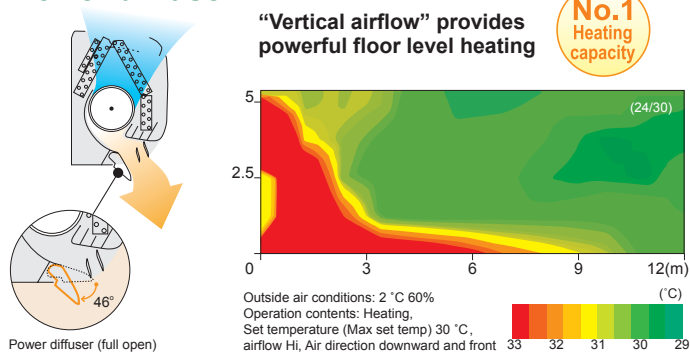

## Air conditioner filter features

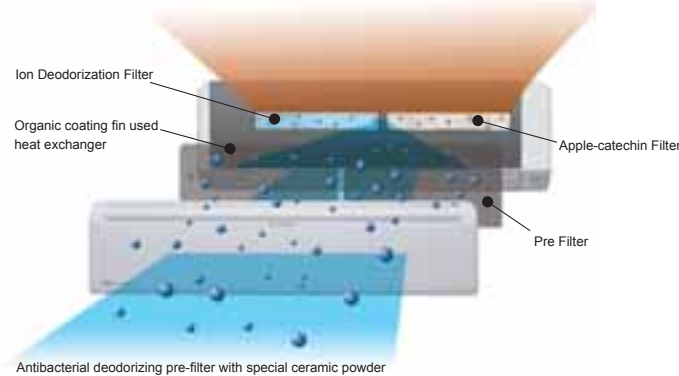

**Long-life\* Ion Deodorization Filter**  
The filter deodorizes by powerfully decomposing absorbed odors using the oxidizing and reducing effects of ions generated by the ultra-fine-particle ceramic.  
(\*The filter can be used for approx. 3 years if it is washed under water to restore its surface action when it is dirty.)

**Apple-catechin Filter**  
Fine dust, invisible mold spores, and harmful microorganisms are absorbed onto the filter by static electricity, and further growth is inhibited and deactivated by the polyphenol extracted from apples.

Using different filters at both sides

## Flexible Installation

	18 type	24 type	30 type
Max. Piping Length	25m	30m	50m
Max. Height	20m	20m	30m

## Easy maintenance

Simplification of drain pan cleaning improves maintenance-ability.

## Low ambient

High efficiency compressor and newly added sensor for monitoring the refrigerant temperature makes possible fine-tuned inverter control which, in turns, make it possible to correspond to lower outdoor temperatures.

Cooling	Heating
-10 to 43°C	-15 to 24°C

## SPECIFICATIONS

Model No.	TENTATIVE			
	Indoor Unit	AS YA18LE	AS YA24LC	AS YA30LC
Reference	Outdoor Unit	AOYR18LE	AOYR24LC	AOYR30LC
Input Power	V/ø/Hz	230/1/50	230/1/50	230/1/50
Capacity	Cooling	5.2	7.10(0.9~8.0)	8.00(2.9~9.0)
	Heating	6.3	8.10(0.9~10.6)	9.00(2.2~11.0)
Power Consumption	Cooling/Heating	1.48/1.68	2.21/2.24	2.66/2.64
EER - Energy Class	Cooling	3.51-A	3.21-A	3.01-B
COP - Energy Class	Heating	3.75-A	3.62-A	3.41-B
Running Current	Cooling/Heating	A	9.7/9.8	11.7/11.6
Moisture Removal	l/h	—	3.0	3.4
Noise (Indoor)	Cooling   H/M/L/Q	44/ - / - /25	47/41/36/32	47/41/36/32
Noise (Outdoor)	Cooling	50	52	53
Airflow (High)	Indoor/Outdoor	m³/h	1100/2340	1100/3600
Net Dimension H x W x D	Indoor	mm	320x998x228	320x998x228
		kg(lbs)	14(31)	14(31)
Weight	Outdoor	mm	620x790x298	578x790x315
		kg(lbs)	40(88)	44(97)
Piping Connections(Small/Large)	mm	6.35/15.88	6.35/15.88	9.52/15.88
Drain Pipe Diameter (Inner/Outer)	mm	16/29	16/29	16/29
Max Pipe Length (Chargeless)	m	25	30(15)	50(20)
Max Height Difference	m	20	20	30
Operation Range	Cooling	°C	-10~43	-10~43
	Heating	°C	-15~24	-15~24
Refrigerant		R410A	R410A	R410A

# WALL MOUNTED TYPE











  
 Optional

ASY7UB      ASY9UC      ASY12UC

For ASY7UB/9UC      For ASY12UC











  
 Optional

ASY14UB











  
 Optional

ASY18UB      ASY24UB      ASY30UB

For ASY18/24UB      For ASY30UB

## SPECIFICATIONS

Reference	Model No.		Indoor Unit		ASY7UB	ASY9UC	ASY12UC	ASY14UB	ASY18UB	ASY24UB	ASY30UB
	Outdoor Unit		AOY7UB		AOY9UC	AOY12UC	AOY14UB	AOY18UB	AOY24UB	AOY30UB	
Input Power	V/ø/Hz				230/1/50	230/1/50	230/1/50	230/1/50	230/1/50	230/1/50	230/1/50
Capacity	Cooling	kW			2.20	2.60	3.25	4.25	5.40	6.80	7.90
	Heating				2.30	2.95	3.95	4.80	5.70	7.40	8.40
Power Consumption	Cooling/Heating	kW			0.83/0.75	1.07/0.90	1.35/1.28	1.38/1.27	1.85/1.85	2.40/2.40	2.75/2.75
EER - Energy Class	Cooling				2.65-D	2.43-E	2.41-E	3.08-B	2.92-C	2.83-C	2.87-C
COP - Energy Class	Heating	W/W			3.07-D	3.28-C	3.09-D	3.78-A	3.08-D	3.08-D	3.05-D
Running Current	Cooling/Heating		A			3.9/3.6	4.8/4.1	5.9/5.6	6.1/5.6	8.3/8.3	10.6/10.5
Moisture Removal		l/h				1.0	1.3	1.8	2.0	2.0	2.5
Noise (Indoor)	Cooling		dB(A)	H/M/L/Q		38/35/33/29	40/38/35/30	40/38/36/33	43/40/37/33	41/37.5/34/-	45/42/38/-
Noise (Outdoor)	Cooling			43	46	48	47	52	53	54	
Airflow (High)	Indoor/Outdoor	m³/h			380/1350	540/1350	540/1700	700/1670	800/3200	970/3200	1040/3320
Net Dimension H x W x D	Indoor				257x808x187	257x808x187	257x808x187	275x790x215	320x1120x220	320x1120x220	320x1120x220
Weight	Outdoor	kg(lbs)			8(18)	8(18)	8(18)	9(20)	16(35)	16(35)	16(35)
					535 x 650 x 250	535x650x250	535 x 695 x 250	535x780x250	650x830x320	650x830x320	900X900X350
Piping Connections(Small/Large)					6.35/9.52	6.35/9.52	6.35/9.52	6.35/12.7	6.35/15.88	9.52/15.88	9.52/15.88
Drain Pipe Diameter (Inner/Outer)					14/25.5	14/25.5	14/25.5	14/25.5	16/28	16/28	16/28
Max Pipe Length (Chargeless)					10(7.5)	15(7.5)	15(7.5)	15(7.5)	20(7.5)	20(7.5)	25(7.5)
Max Height Difference					5	8	8	8	8	8	15
Operation Range	Cooling	°C			21~43	21~43	21~43	21~43	0~43	0~43	0~43
	Heating				-5~24	-5~24	-5~24	-5~24	-6~24	-6~24	-6~24
Refrigerant					R410A	R410A	R410A	R410A	R410A	R410A	R410A

# INVERTER

## FLOOR TYPE

Simple & Thin design harmonizes with the interior



Wired R.C.

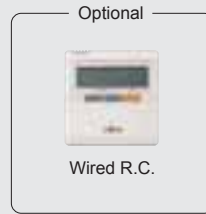

CLASS ALL  
A DC  
AGYF09LA

CLASS ALL  
A DC  
AGYF12LA

CLASS ALL  
A DC  
AGYF14LA

### Flexible & easy installation

Beneath standard window

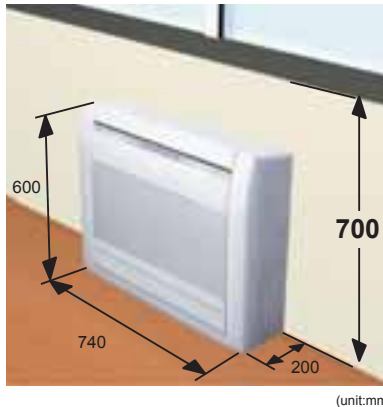

Standard concave portion



Wall



Half concealed (Optional parts necessary)

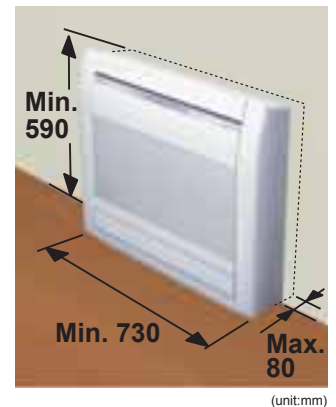

### 2-Fan & Wide airflow

#### Cooling

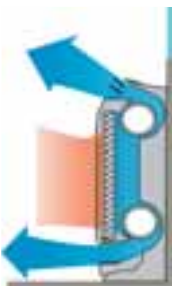

Prevents cold air from falling



#### Heating

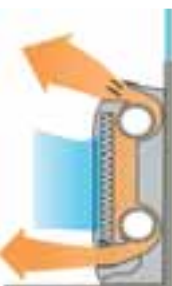

Prevents cold draft from window



### 10°C HEAT Operation

The room temperature can be set to go no lower than 10°C, thus ensuring that the room does not get too cold when not occupied

Caution)

- When the room temperature is higher than 10°C, "10°C HEAT" operation does not start. Operation starts and maintains the room temperature at 10°C for 48 hours when the temperature drops below 10°C.
- When "10°C HEAT" operation stops, the room set temperature quickly returns to the preset temperature.

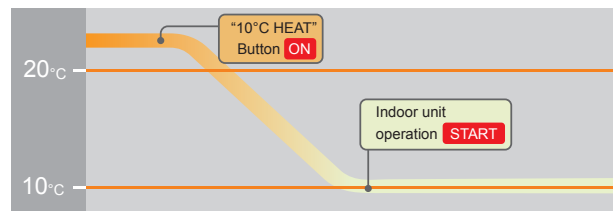

## Choice of 6-direction drain & piping connection

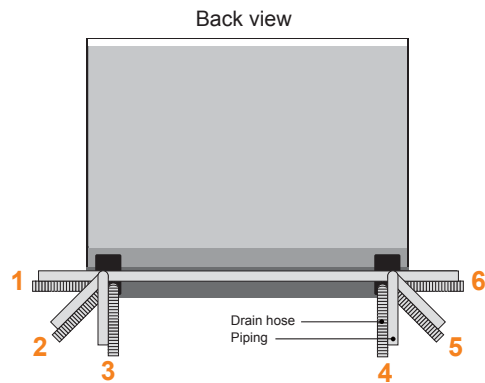

## Air conditioner filter features



### Long-life\* Ion Deodorization Filter

The filter deodorizes by powerfully decomposing absorbed odors using the oxidizing and reducing effects of ions generated by the ultra-fine-particle ceramic.

(\*The filter can be used for approx. 3 years if it is washed under water to restore its surface action when it is dirty.)

+ Using different filters at both sides



### Apple-catechin Filter

Fine dust, invisible mold spores, and harmful microorganisms are absorbed onto the filter by static electricity, and further growth is inhibited and deactivated by the polyphenol extracted from apples.

### Apple-catechin Filter

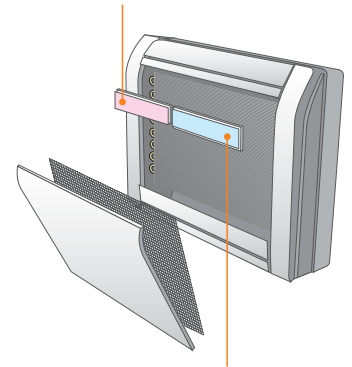

### Ion Deodorization Filter

## Quiet operation

Industry leading noise levels

Fan speed	Noise level
Quiet	22dB(A)

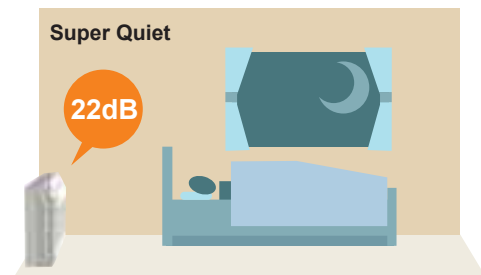

## Built-in timers

### Weekly timer

Possible to set ON/OFF time to operate twice each day of the week



Easy-to-understand time bar display

Setup screen example  
(Set to Wednesday: 8:00 to 20:00)

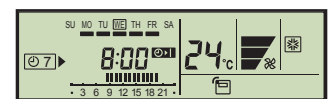

Screen after setup

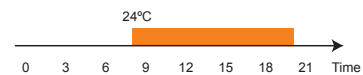

### Setback timer

Possible to set temperature for two time spans and for each day of the week

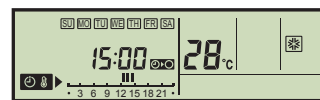

Setup screen example  
(Set from Sunday to Saturday: 12:00 to 15:00, 28°C)

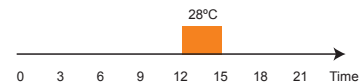

### At "Weekly timer" + "Set back timer" setting

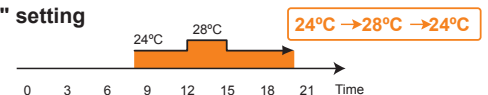

## Low ambient

High efficiency compressor and newly added sensor for monitoring the refrigerant temperature makes possible fine-tuned inverter control which, in turns, make it possible to correspond to lower outdoor temperatures.

Cooling	Heating
-10 to 43°C	-15 to 24°C

## Washable panel

Since the panel is removed and washed easily, it is always clean.

Removable panel



## Optional parts

Wired Remote Controller: UTB-YUD

Half Concealed Kit: UTR-STA

## SPECIFICATIONS

Reference	Model No.	Indoor Unit		AGYF09LA	AGYF12LA	AGYF14LA
		Outdoor Unit		AOYV09LA	AOYV12LA	AOYV14LA
Input Power			V/ø/Hz	230/1/50	230/1/50	230/1/50
Capacity	Cooling		kW	2.60(0.9~3.5)	3.50(0.9~4.0)	4.20(0.9~5.0)
	Heating		kW	3.50(0.9~5.5)	4.50(0.9~6.6)	5.20(0.9~8.0)
Power Consumption	Cooling/Heating		kW	0.53/0.79	0.94/1.19	1.14/1.44
EER - Energy Class	Cooling		W/W	4.91-A	3.72-A	3.68-A
COP - Energy Class	Heating		W/W	4.43-A	3.78-A	3.61-A
Running Current	Cooling/Heating		A	2.6/3.8	4.4/5.5	5.2/6.4
Moisture Removal			l/h	1.3	1.8	2.1
Noise (Indoor)	Cooling	H/M/L/Q	dB(A)	40/35/29/22	40/35/29/22	44/38/31/22
Noise (Outdoor)	Cooling		dB(A)	47	48	50
Airflow (High)	Indoor/Outdoor		m³/h	570/1680	570/1680	650/1910
Net Dimension H x W x D	Indoor		mm	600x740x200	600x740x200	600x740x200
			kg(lbs)	14(31)	14(31)	14(31)
			mm	540x790x290	540x790x290	578x790x300
Weight	Outdoor		kg(lbs)	36(79)	36(79)	40(88)
			kg(lbs)	6.35/9.52	6.35/9.52	6.35/12.7
Piping Connections(Small/Large)			mm	16/29	16/29	16/29
Drain Pipe Diameter (Inner/Outer)			m	20(15)	20(15)	20(15)
Max Pipe Length (Chargeless)			m	15	15	15
Max Height Difference			°C	-10~43	-10~43	-10~43
Operation Range	Cooling		°C	-15~24	-15~24	-15~24
	Heating		°C	-15~24	-15~24	-15~24
Refrigerant				R410A	R410A	R410A

# MULTI TYPE SYSTEMS

2 ROOMS



CLASS  
**A**

AOY18LMAK2  
AOY24LMAM2

3 ROOMS



CLASS **A** ALL  
**DC**

AOYA18LAT3  
AOYA24LAT3

4 ROOMS



CLASS  
**A**

AOY30LMAW4

## Energy Saving

High Efficiency DC Inverter Multi system permits energy saving operation and 40% higher efficiency than a Constant-Speed Multi system. Improved Inverter cooling ratio prevents decrease in capacity under overload operation.

Energy Saving Over a Year's Time



## DC Twin Rotary Compressor

Efficiency is improved over a wide range from high-speed rotation at high load up to the low-speed rotation region at low-load where long-term use is especially frequent, and high power is produced with little power consumption. Also, twin rotor provides low-vibration and quiet operation.

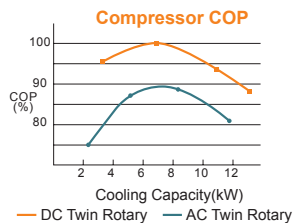

## Flexible Installation

The outdoor unit can be installed in a wide range of properties by the long piping of 30m (gas chargeless) for AOY18LMAK2/24LMAM2, 50m (gas chargeless up to 30m) for AOYA18/24LAT3 and 70m (gas chargeless up to 50m) for AOY30LMAW4.

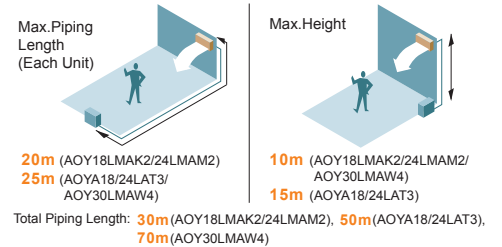

- |                                     |  |   |
|-------------------------------------|--|---|
| 2 Rooms (18type) 1 O.U. to 2 I.U.   | Total capacity of indoor units 4.1-7.0kW can be connected  | 8 varieties of connections in 2 I.U.  |
| 3 Rooms (18type) 1 O.U. to 2-3 I.U. | Total capacity of indoor units 4.1-8.8kW can be connected  | 9 varieties of connections in 2 I.U. / 9 varieties of connections in 3 I.U.   |
| 2 Rooms (24type) 1 O.U. to 2 I.U.   | Total capacity of indoor units 4.1-8.8kW can be connected  | 13 varieties of connections in 2 I.U.   |
| 3 Rooms (24type) 1 O.U. to 2-3 I.U. | Total capacity of indoor units 4.1-10.6kW can be connected | 12 varieties of connections in 2 I.U. / 18 varieties of connections in 3 I.U. |
| 4 Rooms (30type) 1 O.U. to 3-4 I.U. | Total capacity of indoor units 7.9-14.4kW can be connected | 47 varieties of connections in 3 I.U. / 44 varieties of connections in 4 I.U. |

	WALL MOUNTED TYPE	FLOOR TYPE	FLOOR/CEILING UNIVERSAL TYPE	COMPACT DUCT TYPE	COMPACT CASSETTE TYPE	
<b>2.0kW</b> (7,000BTU)	ASYA07LA 					2 ROOMS (18 type) 3 ROOMS (18 type) 2 ROOMS (24 type) 3 ROOMS (24 type) 4 ROOMS (30 type)
<b>2.6kW</b> (9,000BTU)	ASYA09LA 	AGYF09LA 		ARYF09LA 	AUYF09LA 	
<b>3.5kW</b> (12,000BTU)	ASYA12LA 	AGYF12LA 		ARYF12LA 	AUYF12LA 	
<b>4.1kW</b> (14,000BTU)	ASYA14LA 	AGYF14LA 	ABYF14LA 	ARYF14LA 	AUYF14LA 	
<b>5.3kW</b> (18,000BTU)	ASYA18LA 		ABYF18LA 	ARYF18LA 	AUYF18LA 	
<b>6.4kW</b> (22,000BTU)				ARYF22LA 		
<b>7.0kW</b> (24,000BTU)	ASY24LB 		ABYF24LA 			



Select any type of air conditioners you like to suit the atmosphere of your room

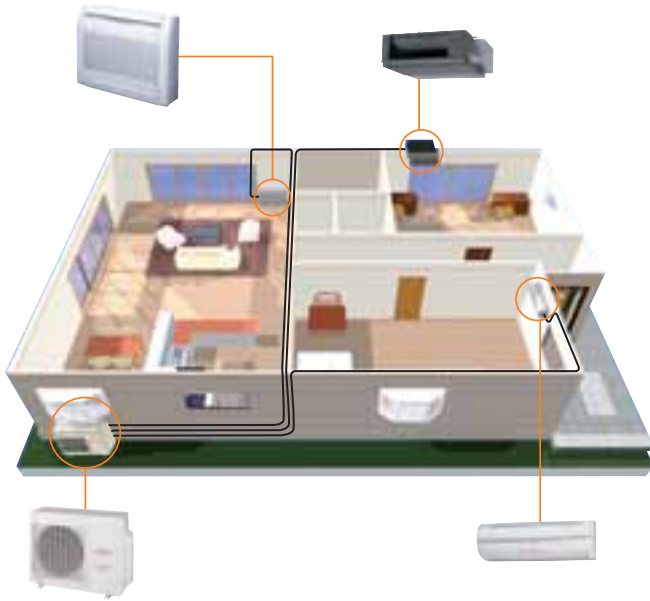

Model No.	Up/Down	Double	Adjust	Restart	Auto Changeover	Distributing	Fresh	Fresh	Economy	Sleep	Program	W.S	Ion	AF	Wash
ASYA07LA/09LA/12LA/14LA/18LA	●		●	●	●					●	●		●	●	●
ASY24LB		●	●	●	●					●	●		●	●	●
AGYF09LA/12LA/14LA	●		●	●	●					●	●		○	○	●
AUYF09LA/12LA/14LA/18LA	●		●	●	●	●	●			●	●		○	○	●
ABYF14LA/18LA/24LA		●	●	●	●					●	●		○		
ARYF09LA/12LA/14LA/18LA/22LA			●	●	●					○	●		○		●

○ : Optional function

**SPECIFICATIONS (WALL MOUNTED TYPE)**

Model No.	Indoor Unit	ASYA07LA	ASYA09LA	ASYA12LA	ASYA14LA	ASYA18LA	ASY24LB
Input Power	V/ø/Hz	230/1/50	230/1/50	230/1/50	230/1/50	230/1/50	230/1/50
Noise	Cooling H/M/L/Q dB(A)	35/32/27/21	38/33/28/22	39/34/28/23	45/38/33/26	45/38/34/28	47/41/36/32
Airflow (High)	m <sup>3</sup> /h	500	550	580	700	660	1020
Net Dimension H x W x D	mm	275x790x215	275x790x215	275x790x215	275x790x215	275x790x215	320x1120x220
Weight	kg(lbs)	9(20)	9(20)	9(20)	9(20)	9(20)	16(35)

**SPECIFICATIONS (FLOOR TYPE, FLOOR/CEILING UNIVERSAL TYPE)**

Model No.	Indoor Unit	AGYF09LA	AGYF12LA	AGYF14LA	ABYF14LA	ABYF18LA	ABYF24LA
Input Power	V/ø/Hz	230/1/50	230/1/50	230/1/50	230/1/50	230/1/50	230/1/50
Noise	Cooling H/M/L/Q dB(A)	39/34/29/22	42/36/30/22	44/38/31/22	36/34/32/29	43/41/38/35	48/46/43/40
Airflow (High)	m <sup>3</sup> /h	530	600	650	640	780	880
Net Dimension H x W x D	mm	600x740x200	600x740x200	600x740x200	199x990x655	199x990x655	199x990x655
Weight	kg(lbs)	14(30.7)	14(30.7)	14(30.7)	27(60)	27(60)	27(60)

**SPECIFICATIONS (COMPACT CASSETTE TYPE)**

Model No.	Indoor Unit	AUYF09LA	AUYF12LA	AUYF14LA	AUYF18LA
Input Power	V/ø/Hz	230/1/50	230/1/50	230/1/50	230/1/50
Noise	Cooling H/M/L/Q dB(A)	34/31/29/26	37/33/31/27	40/35/32/27	42/37/33/27
Airflow (High)	m <sup>3</sup> /h	540	610	680	750
Net Dimension H x W x D	mm	245x570x570	245x570x570	245x570x570	245x570x570
Weight	kg(lbs)	15(33.1)	15(33.1)	15(33.1)	15(33.1)
Grille	UTG-UFYB-W				

**SPECIFICATIONS (COMPACT DUCT TYPE)**

Model No.	Indoor Unit	TENTATIVE ARYF09LA	TENTATIVE ARYF12LA	TENTATIVE ARYF14LA	TENTATIVE ARYF18LA	TENTATIVE ARYF22LA
Input Power	V/ø/Hz	230/1/50	230/1/50	230/1/50	230/1/50	230/1/50
Noise	Cooling H/M/L/Q dB(A)	-	-	-	-	-
Airflow (High)	m <sup>3</sup> /h	480	630	820	850	1060
Net Dimension H x W x D	mm	217x663x595	217x953x595	217x953x595	217x953x595	217x953x595
Weight	kg(lbs)	18(40)	23(51)	23(51)	23(51)	23(51)

**SPECIFICATIONS (2 ROOMS, 3 ROOMS, 4 ROOMS)**

Model No.	Outdoor Unit	AOY18LMAK2	AOY24LMAM2	AOYA18LAT3	AOYA24LAT3	AOY30LMAW4
Input Power	V/ø/Hz	230/1/50	230/1/50	230/1/50	230/1/50	230/1/50
Noise	Cooling dB(A)	49	49	46	48	50
Net Dimension H x W x D	mm	650x830x320	650x830x320	700x900x330	700x900x330	830x900x330
Weight	kg(lbs)	56(123)	56(123)	55(121)	55(121)	68(150)
Piping Connections (Small/Large)	mm	6.35/9.52	6.35/9.52	6.35/9.52x2	6.35/9.52x2	6.35/9.52x2
		6.35/*12.70	6.35/*12.70	6.35/*12.70	6.35/*12.70	6.35/*12.70x2
Max Pipe Length (Chargeless)	m	30(Total)	30(Total)	50(Total)	50(Total)	70(Total)
Max Height Difference		10(Each)	10(Each)	15(Each)	15(Each)	10(Each)
Operation Range	Cooling °C	0~46	0~46	-10~46	-10~46	0~46
	Heating °C	-10~24	-10~24	-15~24	-15~24	-10~24
Refrigerant		R410A	R410A	R410A	R410A	R410A

\*Connect to connection valve by the adapter.





# INVERTER

## COMPACT CASSETTE TYPE

Powerful wide air flow & Quiet operation

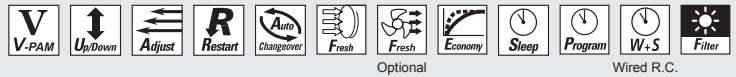

Optional

Wired R.C.



Grille is an option

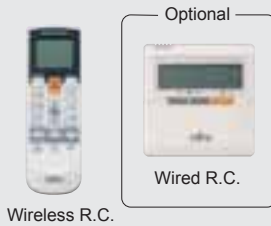

Wireless R.C.

Wired R.C.



For AU YF12/14LA



For AU YF18LA / AU YA24LB



CLASS A ALL DC  
AU YF12LA

CLASS A ALL DC  
AU YF14LA

CLASS A ALL DC  
AU YF18LA

CLASS A ALL DC  
AU YA24LB

### 2-stage turbo fan **WORLD FIRST** \*1

High efficiency design by 2 stage structure

#### Conventional turbo fan

In case of conventional fan, airflow move to motor side which made air outlet range narrow, and velocity of air passing through heat exchanger was uneven.



#### 2-stage turbo fan

2 stages of airflow attracting each other produced by 2 stage structure of new fan, realize airflow spreading constantly and widely to heat exchanger.

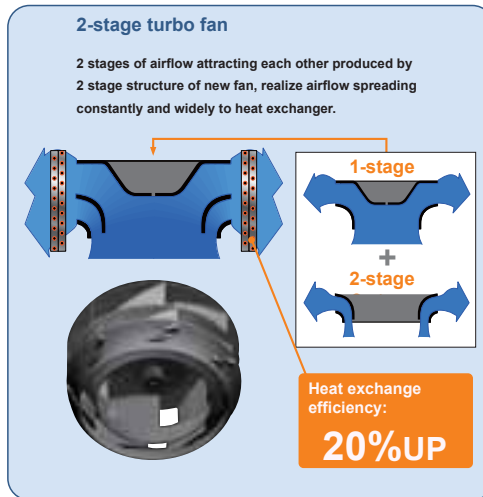

### Quiet quality

#### Optimization of wing form (laminar wing type) and wing number (7 blades each)

Designed by CFD-analysis (fluid) simulations

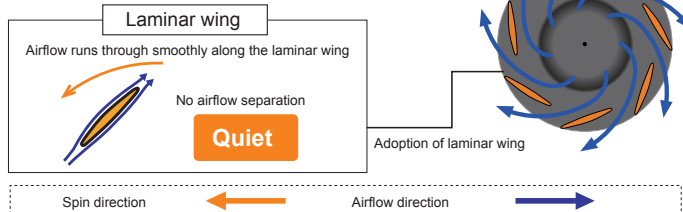

#### Quiet operation

Top class cooling mode noise level in the industry attained

Fan speed	Noise level			
	12 type	14 type	18 type	24 type
High	37dB	38dB	38dB	49dB
Med	34dB	34dB	34dB	44dB
Low	30dB	30dB	30dB	36dB
Quiet	27dB	27dB	26dB	30dB

### High efficiency heat exchanger

Indoor unit heat exchanger (12/14/18 type)

Shape changed from round bending to corner bending

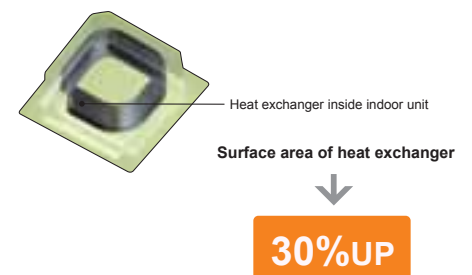

\*1:October 18, 2006, announcement at IKK2006. As fan for air conditioner (Our company's investigation)

\*2:As of January 2006, size of outdoor unit minimized in 5.3kW and 7.0kW class European size (compact) ceiling cassette air conditioner. (Our company's investigation)

## Easy maintenance

### ① Maintenance of fan motor and fan

Maintenance of fan motor and fan can be done easily after taking off the panel, since bell-mouth can be removed easily

A : Fan motor    B : 2-stage turbo fan  
C : Bell-mouth    D : Panel

### ② Long life filter

: standard equipment

### ③ Adaptation of transparent drainage parts

Easy check of operation of drain-up kit when you install

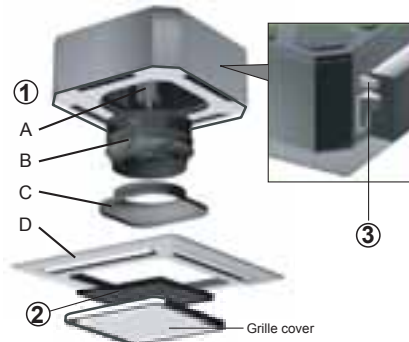

## Compact design

World first 24 type model in compact cassette category **WORLD FIRST** \*2

(Easy installation by taking off ceiling panel of 600 x 600 size)

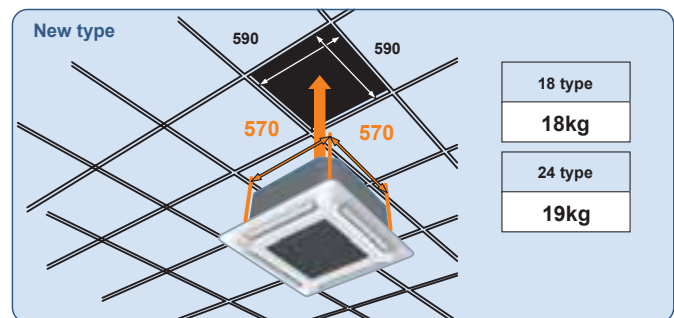
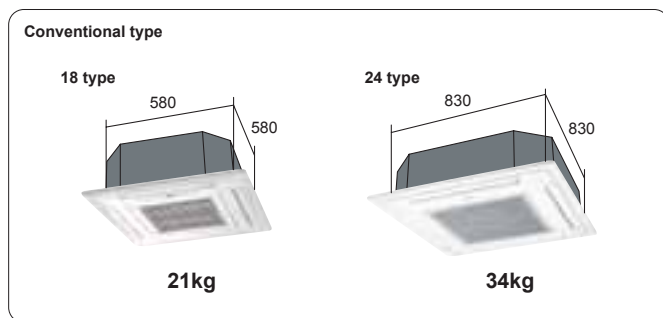

## Easy installation

Various work setting done from remote controller at the time of installation

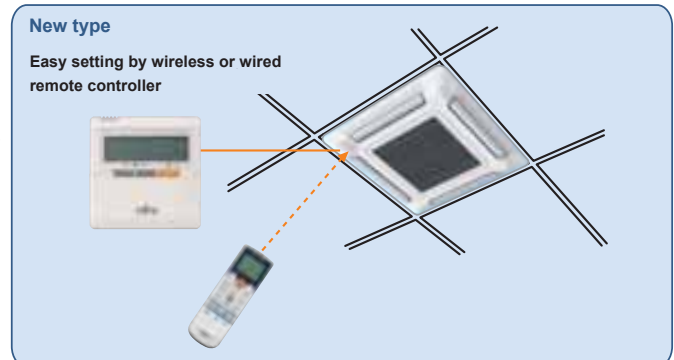
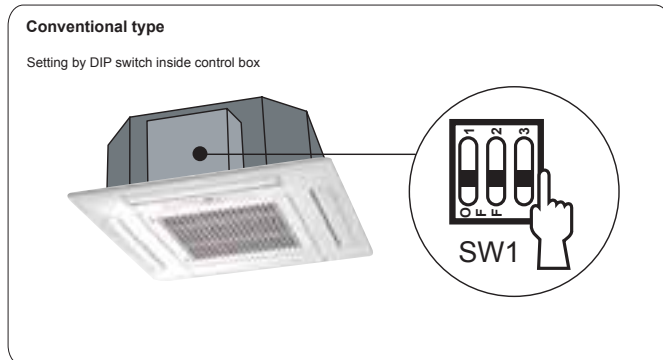

## High ceiling mode

Air reaches sufficiently up to 3.5m height, even it is compact cassette type

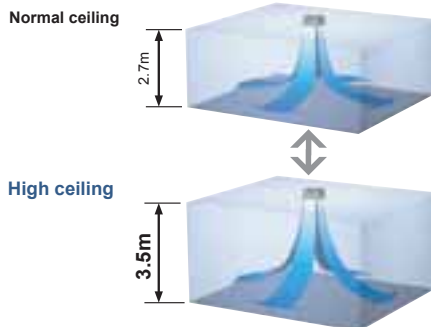

## SPECIFICATIONS

Model No.	Indoor Unit		AUYF12LA	AUYF14LA	AUYF18LA	AUYA24LB
	Outdoor Unit		AOYA12LA	AOYA14LA	AOYA18LA	AOYA24LA
Input Power		V/ø/Hz	230/1/50	230/1/50	230/1/50	230/1/50
Capacity	Cooling	kW	3.50	4.30	5.20	7.10
	Heating	kW	4.10	5.00	6.00	8.00
Power Consumption	Cooling/Heating	kW	1.05/1.11	1.33/1.34	1.62/1.66	2.21/2.21
EER - Energy Class	Cooling		3.33-A	3.21-A	3.21-A	3.21-A
COP - Energy Class	Heating	W/W	3.69-A	3.71-A	3.61-A	3.61-A
Running Current	Cooling/Heating	A	4.6/4.9	5.8/5.9	7.1/7.3	9.7/9.7
Moisture Removal		l/h	1.2	1.5	2.2	2.7
Noise (Indoor)	Cooling	H/M/L/Q	37/34/30/27	38/34/30/27	38/34/30/26	49/44/36/30
Noise (Outdoor)	Cooling	dB(A)	47	49	50	52
Airflow (High)	Indoor/Outdoor	m³/h	600/1780	680/1910	680/2000	930/2470
Net Dimension	Indoor/Grille	mm	245×570×570/ 50×700×700	245×570×570/ 50×700×700	245×570×570/ 50×700×700	245×570×570/ 50×700×700
		kg(lbs)	15(33)/2.6(6)	15(33)/2.6(6)	15(33)/2.6(6)	17(37)/2.6(6)
Weight	Outdoor	mm	578×790×300	578×790×300	578×790×300	578×790×315
		kg(lbs)	40(88)	40(88)	40(88)	44(97)
Piping Connections(Small/Large)		mm	6.35/9.52	6.35/12.70	6.35/12.70	6.35/15.88
Drain Pipe Diameter (Inner/Outer)		mm	19.4/25.4	19.4/25.4	19.4/25.4	19.4/25.4
Max Pipe Length (Chargeless)		m	25	25	25	30
Max Height Difference		m	15	15	15	20
Operation Range	Cooling	°C	-10~46	-10~46	-10~46	-10~46
	Heating	°C	-15~24	-15~24	-15~24	-15~24
Refrigerant			R410A	R410A	R410A	R410A
Grille			UTG-UFYB-W	UTG-UFYB-W	UTG-UFYB-W	UTG-UFYB-W

## Optional parts

Wired Remote Controller: UTB-YUD

Air Outlet Shutter Plate: UTR-YDZB

# INVERTER

## CASSETTE TYPE

Powerful wide air flow & Quiet operation

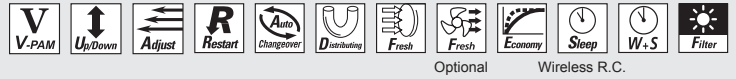

Grille is an option



**CLASS A**  
ALL DC  
AUYA30LB

**CLASS A**  
ALL DC  
AUYA36LB

### Powerful wide flow & Quiet operation

High efficiency turbo fan with 3-dimensional wing

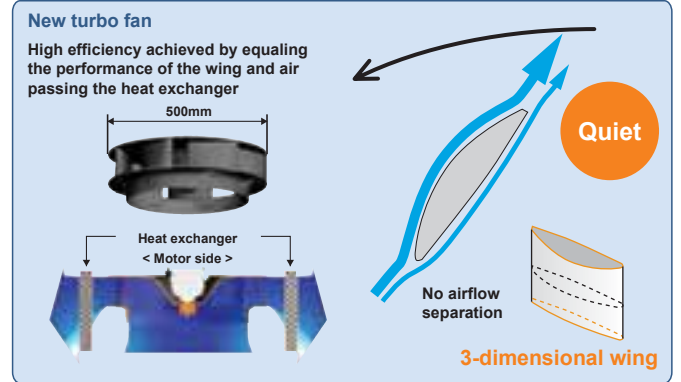
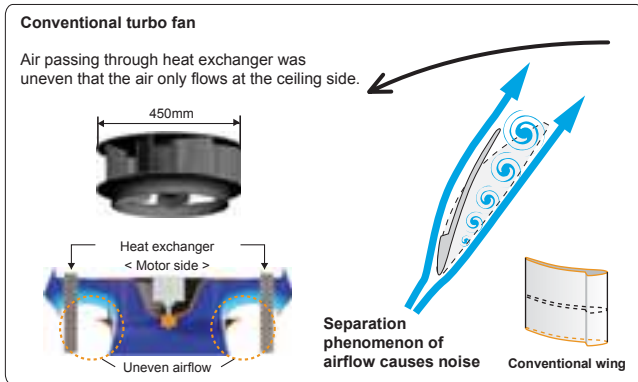

← : Spin direction → : Airflow direction ••••• : Turbulent flow noise

### Improvement of the flap

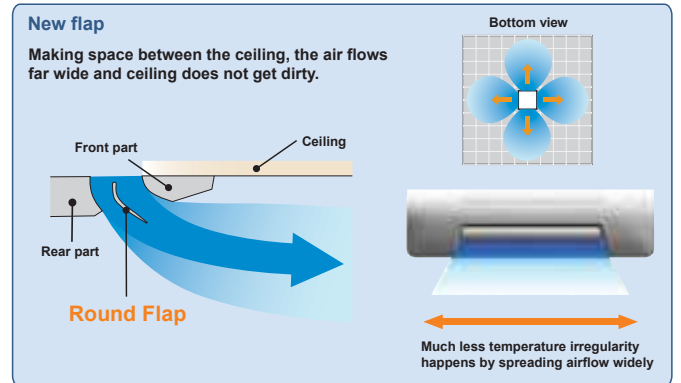
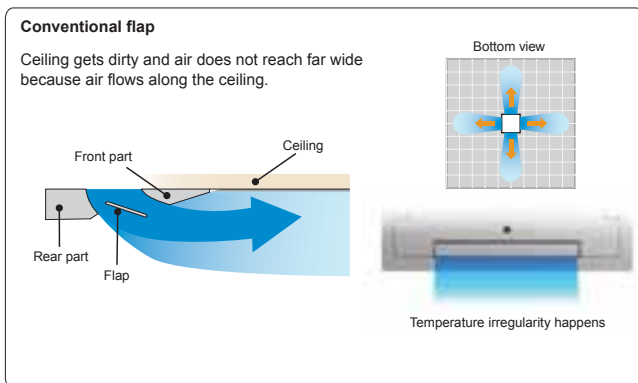

### Quiet operation

Fan speed	Noise level	
	30 type	36 type
High	40dB	43dB
Med	38dB	38dB
Low	36dB	36dB
Quiet	32dB	32dB



## Wide & powerful airflow

### Airflow range when the flap is upward

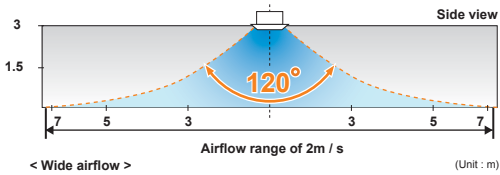

< Wide airflow >  
Powerful performance lets the airflow reach far wide

### Airflow range when the flap is downward

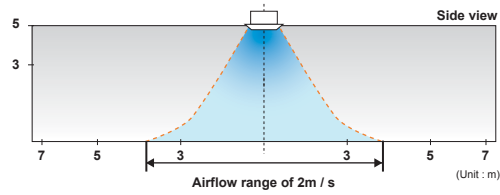

## High lift drain pump



## Adjustment of knot is possible after installation

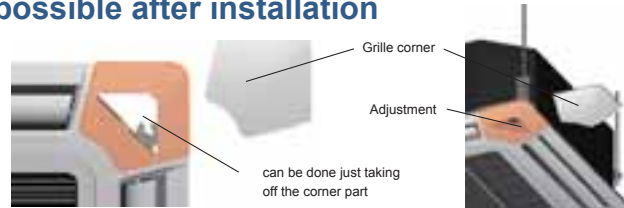

## Built-in timers

### Weekly timer

Possible to set ON/OFF time to operate twice each day of the week



Setup screen example  
(Set to Wednesday: 8:00 to 20:00)

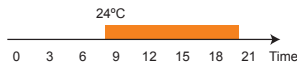

### Setback timer

Possible to set temperature for two time spans and for each day of the week

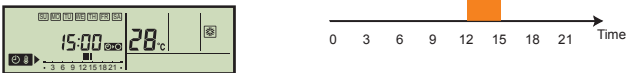

Setup screen example  
(Set from Sunday to Saturday: 12:00 to 15:00, 28°C)

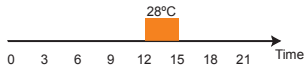

### At "Weekly timer" + "Set back timer" setting

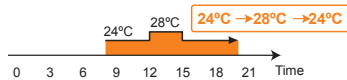

## Filter sign

Announces timing of changing the filter

## One way aperture installation

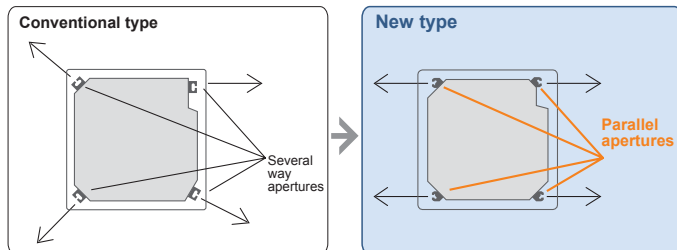

## Optional parts

- IR Receiver Kit: UTY-LRHYA1
- Wide Panel: UTG-AGYA-W
- Panel Spacer: UTG-BGYA-W
- Air Outlet Shutter Plate: UTR-YDZC
- Fresh Air Intake Kit: UTY-VXGA

## SPECIFICATIONS

Model No.	Indoor Unit	Outdoor Unit	TENTATIVE	TENTATIVE
			AUYA30LB	AUYA36LB
Reference			AOYA30LB	AOYA36LB
Input Power		V/ø/Hz	230/1/50	230/1/50
Capacity	Cooling	kW	8.50	10.00
	Heating	kW	10.00	11.20
Power Consumption	Cooling/Heating	kW	2.65/2.77	3.11/3.02
EER - Energy Class	Cooling	W/W	3.21-A	3.21-A
COP - Energy Class	Heating	W/W	3.61-A	3.71-A
Running Current	Cooling/Heating	A	11.6/12.2	13.7/13.3
Moisture Removal		l/h	2.50	3.50
Noise (Indoor)	Cooling	H/M/L/Q	40/38/36/32	43/38/36/32
Noise (Outdoor)	Cooling		54	54
Airflow (High)	Indoor/Outdoor	m³/h	1600/3600	1800/4000
Net Dimension H x W x D	Indoor/Grille	mm	288×840×840	288×840×840
		kg(lbs)	50×950×950	50×950×950
Weight	Outdoor	mm	830×900×330	830×900×330
		kg(lbs)	62(136)	62(136)
Piping Connections(Small/Large)		mm	9.52/15.88	9.52/15.88
Drain Pipe Diameter (Inner/Outer)		mm	22.0/25.6	22.0/25.6
Max Pipe Length (Chargeless)		m	50	50
Max Height Difference		m	30	30
Operation Range	Cooling	°C	-15~46	-15~46
	Heating	°C	-15~24	-15~24
Refrigerant			R410A	R410A
Grille			UTG-UGYA-W	UTG-UGYA-W

# CASSETTE TYPE

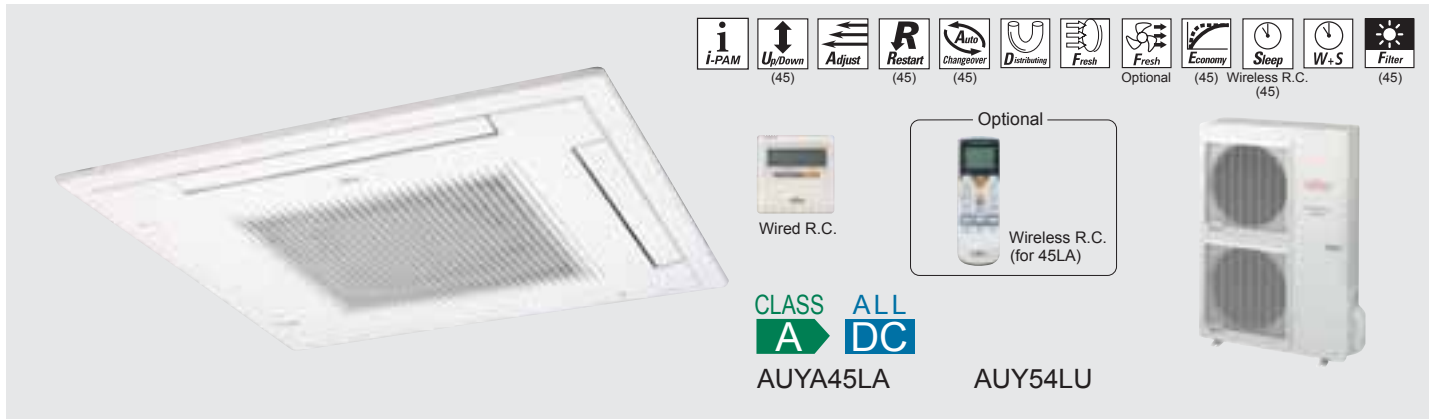

## Comfortable airflow

### 4 step swing

Auto air flow direction and auto swing

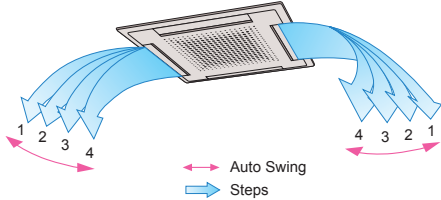

### 2-4 way air flow system

Select 2-way, 3-way or 4-way air flow to suit your needs.

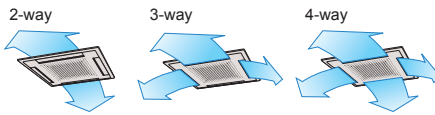

### Wide air flow

Larger air flap distributes the outlet air flow a longer distance in the horizontal direction.

## Flexible installation

Installation is done by "Standard setting" with more than 300mm of space. "Slender setting" lets it suitable for minimum 265mm installation space.

Installation Space (Built-in measurement)

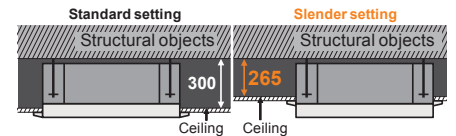

## Duct connection hole opening

Fresh air can be introduced through this opening

Conditioned air can be distributed by means of a distribution duct

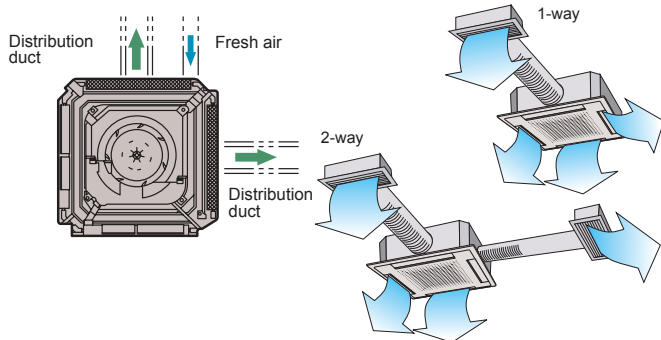

## Easy installation (For 45LA)

Main work settings can be done easily from the remote controller at installation

### Main work settings

- High ceiling setting
- Auto restart
- Temperature adjustment when cooling / heating

### Conventional type

Setting by DIP switch inside control box

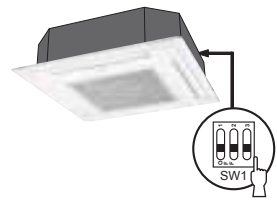

### Setting by wireless or wired remote controller

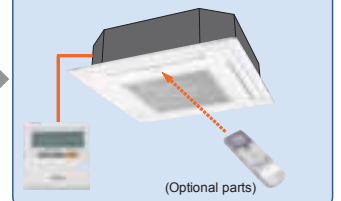

## Condensate pump lift to 800mm

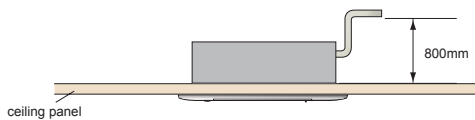

## Optional parts

Wireless Remote Controller: UTB-YNA (For 45LA)

Additional Grille: UTG-AGEA-W

Simple Remote Controller: UTB-YPB (For 54LU)

## SPECIFICATIONS

Model No.	Indoor Unit		AUYA45LA	AU54LU
	Outdoor Unit		AOYA45LA	AOY54LU
Reference				
Input Power	V/ø/Hz		230/1/50	230/1/50
Capacity	Cooling	kW	12.50	13.30
	Heating	kW	14.00	16.00
Power Consumption	Cooling/Heating	kW	3.89/3.77	5.45/4.95
EER - Energy Class	Cooling		3.21-A	2.44
COP - Energy Class	Heating	W/W	3.71-A	3.23
Running Current	Cooling/Heating	A	17.0/16.5	23.8/21.6
Moisture Removal		l/h	4.50	5.50
Noise (Indoor)	Cooling   H/M/L/Q	dB(A)	52/47/42/39	50/48/45
Noise (Outdoor)	Cooling	dB(A)	55	54
Airflow (High)	Indoor/Outdoor	m³/h	1750/6600	1700/6600
Net Dimension H x W x D	Indoor/Grille	mm	296x830x830/ 30x940x940	296x830x830 30x940x940
		kg(lbs)	32(70)/ 7(16)	33(72)/ 7(16)
Weight	Outdoor	mm	1290x900x330	1290x900x330
		kg(lbs)	98(216)	105(231)
Piping Connections(Small/Large)		mm	9.52/15.88	9.52/15.88
Drain Pipe Diameter (Inner/Outer)		mm	32.0/37.0	32.0/37.0
Max Pipe Length (Chargeless)		m	50	70
Max Height Difference		m	30	30
Operation Range	Cooling	°C	-15~46	-15~43
	Heating	°C	-15~24	-15~24
Refrigerant			R410A	R410A



# INVERTER

# FLOOR/CEILING UNIVERSAL TYPE













Wired R.C.



Wireless R.C.

Optional



Wired R.C.





CLASS ALL  
**A** DC

ABYF18LA

CLASS ALL  
**A** DC

ABYF24LA

## Flexible installation

### Example for floor installation

Floor console



### Example for ceiling installation

Under ceiling



## Low ambient

High efficiency compressor and newly added sensor for monitoring the refrigerant temperature makes possible fine-tuned inverter control which, in turns, make it possible to correspond to lower outdoor temperatures.

### 18 type

Conventional type

Cooling	Heating	Cooling	Heating
0 to 43°C	-10 to 24°C	-10 to 46°C	-15 to 24°C

### 24 type

Conventional type

Cooling	Heating	Cooling	Heating
0 to 43°C	-10 to 24°C	-10 to 46°C	-15 to 24°C

## Easy installation

Main work settings can be done easily from the remote controller at installation

### Main work settings

- High ceiling setting
- Auto restart
- Temperature adjustment when cooling / heating

### Conventional type

Setting by DIP switch inside control box

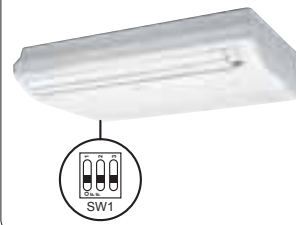

### Setting by wireless or wired remote controller

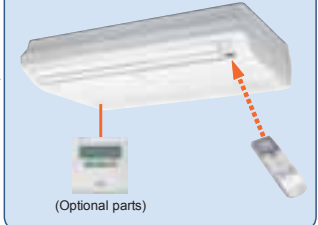

## Double auto swing

A combination of right/left and up/down directional swing allows 3-dimensional air direction control

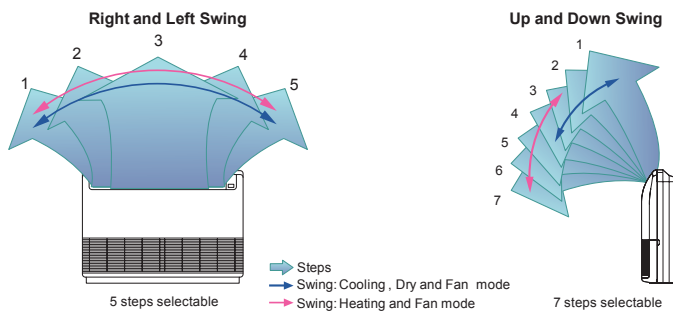

## Optional parts

Wired Remote Controller: UTB-YUD

## SPECIFICATIONS

Reference	Model No.	Indoor Unit		ABYF18LA	ABYF24LA
		Outdoor Unit		AOYA18LA	AOYA24LA
Input Power		V/ø/Hz	230/1/50	230/1/50	
Capacity	Cooling	kW	5.20	7.10	
		Heating	6.00	8.00	
Power Consumption	Cooling/Heating	kW	1.62/1.66	2.21/2.21	
EER - Energy Class	Cooling	W/W	3.21-A	3.21-A	
COP - Energy Class	Heating		3.61-A	3.61-A	
Running Current	Cooling/Heating	A	7.1/7.3	9.7/9.7	
Moisture Removal		l/h	2.0	2.7	
Noise (Indoor)	Cooling	H/M/L/Q	44/41/35/32	49/45/41/36	
Noise (Outdoor)	Cooling		50	52	
Airflow (High)	Indoor/Outdoor	m³/h	780/2000	980/2470	
Net Dimension	Indoor	mm	199x990x655	199x990x655	
		kg(lbs)	27(60)	27(60)	
H x W x D	Outdoor	mm	578x790x300	578x790x315	
		kg(lbs)	40(88)	44(97)	
Piping Connections(Small/Large)			6.35/12.70	6.35/15.88	
Drain Pipe Diameter (Inner/Outer)		mm	21.5/26.0	21.5/26.0	
Max Pipe Length (Chargeless)		m	25	30	
Max Height Difference			15	20	
Operation Range	Cooling	°C	-10~46	-10~46	
	Heating		-15~24	-15~24	
Refrigerant			R410A	R410A	

# INVERTER

# CEILING TYPE

Easily concealed in any installation

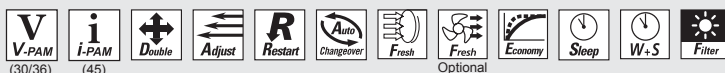

CLASS **A** ALL **DC**

ABYA30LB

**NEW**

CLASS **A** ALL **DC**

ABYA36LB

**NEW**

CLASS **A** ALL **DC**

ABYA45LA



## Installation

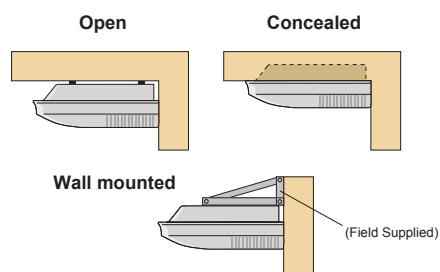

## Multi auto swing, long distance airflow

### Multi auto swing

A combination of right/left and up/down directional swing allows 3-dimensional air direction control.

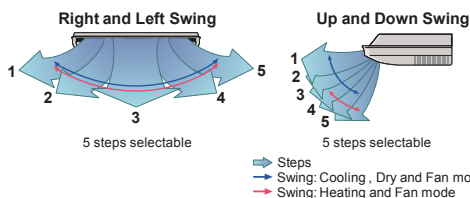

### Long distance airflow

Due to air blasting performance of max. 18m, long-reach airflow is available for both cooling and heating operation.

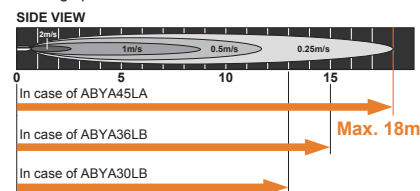

## Easy installation

Main work settings can be done easily from the remote controller at installation

### Main work settings

- High ceiling setting
- Auto restart
- Temperature adjustment when cooling / heating

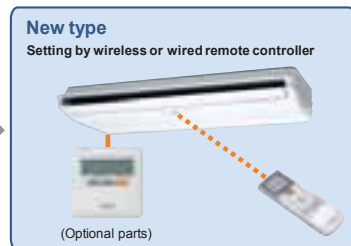
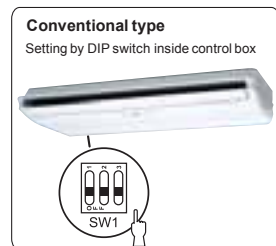

## Light weight & Compact

### Outdoor unit

Drastically downsized compared with the conventional model

### 36 type

Compact size

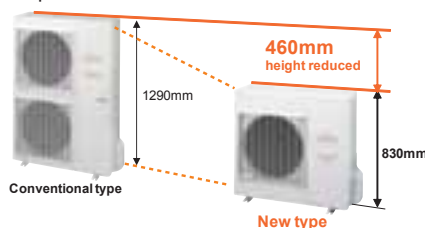

Conventional type	
Height	Weight
1,290 mm	98kg

New type	
Height	Weight
830 mm	62kg

Weight **-37%**

Volume **-36%**

## Slim & Compact design

## Condensate lift-up mechanism (Option)

Optional drain lift-up mechanism allows flexible installation.

**MAX. 500mm**

## Fresh air intake

## Long-life filter

High Efficiency long-life filter doubles the life of the filter compared to standard filters.

## Optional parts

Flange (Round): UTD-RF204

Wired Remote Controller: UTB-YUD

Drain Pump Unit: UTR-DPB24T

## SPECIFICATIONS

Reference	Model No.	Indoor Unit			
		ABYA30LB	ABYA36LB	ABYA45LA	
		Outdoor Unit			
		AOYA30LB	AOYA36LB	AOYA45LA	
Input Power		V/ø/Hz	230/1/50	230/1/50	230/1/50
Capacity	Cooling	kW	8.50	9.40	12.50
	Heating	kW	10.00	11.20	14.00
Power Consumption	Cooling/Heating	kW	2.65/2.77	2.93/3.02	3.89/3.77
EER - Energy Class	Cooling	W/W	3.21-A	3.21-A	3.21-A
COP - Energy Class	Heating	W/W	3.61-A	3.71-A	3.71-A
Running Current	Cooling/Heating	A	11.6/12.1	12.8/13.2	17.0/16.5
Moisture Removal		l/h	2.50	3.00	4.50
Noise (Indoor)	Cooling	H/M/L/Q	45/43/37/32	47/43/37/32	49/45/39/34
Noise (Outdoor)	Cooling		53	54	55
Airflow (High)	Indoor/Outdoor	m³/h	1660/3600	1900/4000	2100/6600
Net Dimension	Indoor	mm	240×1660×700	240×1660×700	240×1660×700
	Outdoor	mm	830×900×330	830×900×330	1290×900×330
Weight	Indoor	kg(lbs)	46(101)	46(101)	46(101)
	Outdoor	kg(lbs)	62(136)	62(136)	98(216)
Piping Connections(Small/Large)			9.52/15.88	9.52/15.88	9.52/15.88
Drain Pipe Diameter (Inner/Outer)		mm	22.0/25.6	22.0/25.6	21.5/26.0
Max Pipe Length (Chargeless)		m	50	50	50
Max Height Difference			30	30	30
Operation Range	Cooling	°C	-15~46	-15~46	-15~46
	Heating	°C	-15~24	-15~24	-15~24
Refrigerant			R410A	R410A	R410A

# INVERTER

# COMPACT DUCT TYPE



**NEW**

**CLASS A ALL DC**  
ARYF12LA

**CLASS A ALL DC**  
ARYF14LA

**CLASS A ALL DC**  
ARYF18LA



Wired R.C.

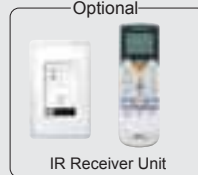

IR Receiver Unit



For ARYF12/14LA



For ARYF18LA

## Flexible installation



Ceiling concealed

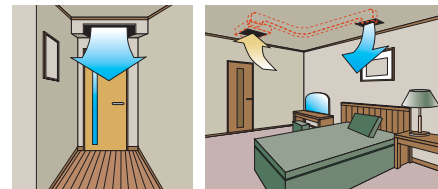

Floor concealed

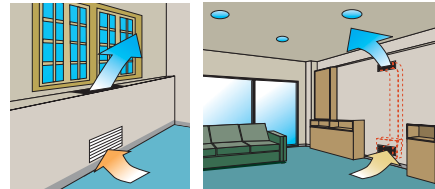

## Air-intake

Air intake direction can be selected to match the installation site

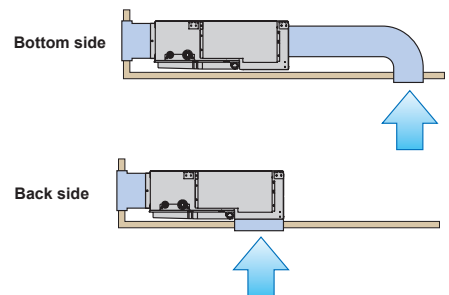

## Static pressure mode setting

Static pressure mode can be selected from 4 modes, to meet wide-ranging installation conditions.

Static pressure range (High speed mode)

ARYF12LA/14LA/18LA **0 to 90 Pa**

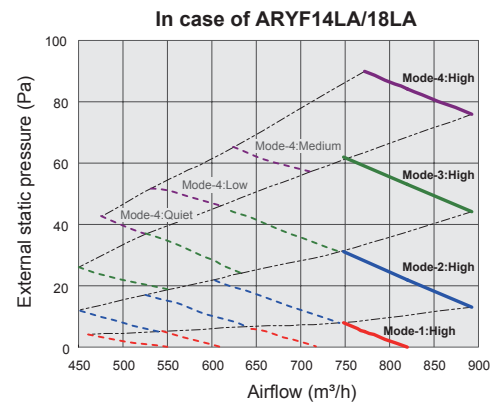
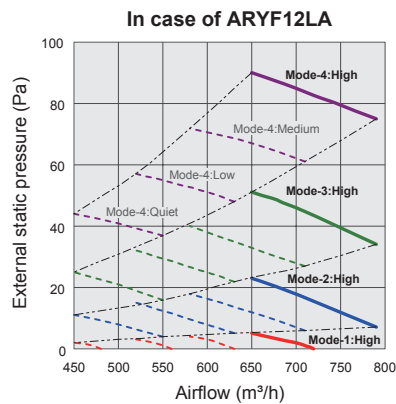

## 2-direction drain piping

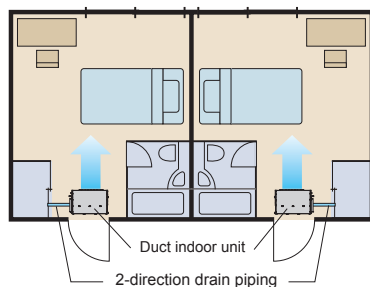

## SPECIFICATIONS

Reference	Model No.	Indoor Unit				
		ARYF12LA	ARYF14LA	ARYF18LA		
		Outdoor Unit				
		AOYA12LA	AOYA14LA	AOYA18LA		
Input Power		V/ø/Hz	230/1/50	230/1/50	230/1/50	
Capacity		Cooling	kW	3.50	4.30	5.20
		Heating	kW	4.10	5.00	6.00
Power Consumption		Cooling/Heating	kW	1.05/1.11	1.33/1.34	1.62/1.66
EER - Energy Class		Cooling	W/W	3.33-A	3.21-A	3.21-A
COP - Energy Class		Heating	W/W	3.69-A	3.71-A	3.61-A
Running Current		Cooling/Heating	A	4.6/4.9	5.8/5.9	7.1/7.3
Moisture Removal			l/h	1.3	1.5	2.0
Noise (Indoor)		Cooling	H/M/L/Q	dB(A)		
Noise (Outdoor)		Cooling		47	49	50
Airflow (High)		Indoor/Outdoor	m³/h	720/1780	820/1910	820/2000
Net Dimension H x W x D		Indoor	mm	217x953x595		
			kg(lbs)	23(51)		
Weight		Outdoor	mm	578x790x300		
			kg(lbs)	40(88)		
Piping Connections(Small/Large)			mm	6.35/9.52		
Drain Pipe Diameter (Inner/Outer)			mm	21.5/26.0		
Max Pipe Length (Chargeless)			m	25		
Max Height Difference			m	15		
Operation Range		Cooling	°C	-10~46		
		Heating	°C	-15~24		
Refrigerant				R410A		

The measurement static pressure is 0 Pa.

## Optional parts

Remote Sensor Unit: UTD-RS100

External Control Set: UTD-ECS5A

Drain Pump Unit: UTZ-PX1BBA

IR Receiver Unit: UTY-LRHY1

# INVERTER

# DUCT TYPE



**CLASS ALL**  
**A DC**

ARYA24LA

**CLASS ALL**  
**A DC**

ARYA30LB

NEW

**CLASS ALL**  
**A DC**

ARYA36LB

NEW

**CLASS ALL**  
**A DC**

ARYA45LA



Wired R.C.



Optional  
IR Receiver Unit



Optional  
Wireless R.C.



For ARYA24LA



For ARYA30/36LB



For ARYA45LA

## Installation styles

### Embedded in Ceiling

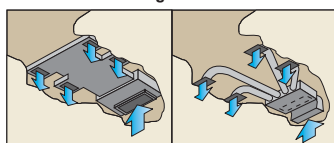

### Hanging from Ceiling

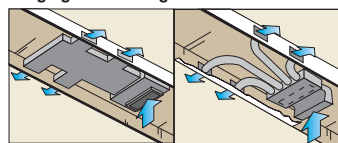

## Easy installation

Main work settings can be done easily from the remote controller at installation

### Main work settings

- Static pressure mode setting
- Auto restart
- Temperature adjustment when cooling/heating

### Conventional type

Setting by DIP switch inside control box

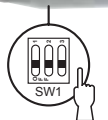

### Setting by wired remote controller



## Easy maintenance

In the case of rear suction type, as seen from lower rear part

Structural improvement is attained by making the bottom panel two pieces, front and rear, and the internal fan casing is also made dismantlable in two pieces, namely, upper and lower ones. The motor and fan maintenance and dismantling can be made easily by removing the rear panel and lower part of the casing with the main chassis installed.

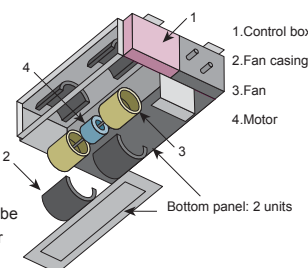

## Built-in timers

### Weekly timer

Possible to set ON/OFF time to operate twice each day of the week

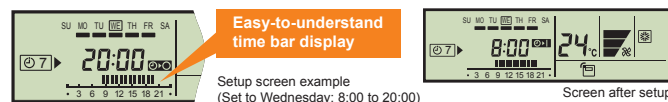

### Setback timer

Possible to set temperature for two time spans and for each day of the week

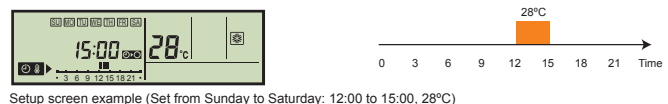

### At "Weekly timer" + "Set back timer" setting

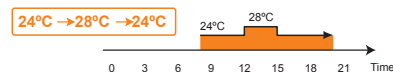

## Optional parts

Flange (Round) : UTD-RF204

Flange (Square) : UTD-SF045T

Long Life Filter : UTD-LF25NA

Remote Sensor Unit : UTD-RS100

External Control Set : UTD-ECS5A

Drain Pump Unit : UTZ-PX1NBA

IR Receiver Unit : UTY-LRHY1



## SPECIFICATIONS

Reference	Model No.	Indoor Unit		ARYA24LA	ARYA30LB	ARYA36LB	ARYA45LA	
		Outdoor Unit		AOYA24LA	AOYA30LB	AOYA36LB	AOYA45LA	
Input Power		V/ø/Hz		230/1/50	230/1/50	230/1/50	230/1/50	
Capacity		Cooling	kW	7.10	8.50	9.40	12.50	
		Heating	kW	8.00	10.00	11.20	14.00	
Power Consumption		Cooling/Heating		kW	2.21/2.21	2.65/2.68	2.93/3.10	3.89/3.77
EER - Energy Class		Cooling		W/W	3.21-A	3.21-A	3.21-A	3.21-A
COP - Energy Class		Heating		W/W	3.61-A	3.73-A	3.61-A	3.71-A
Running Current		Cooling/Heating		A	9.7/9.7	11.6/11.7	12.8/13.6	17.0/16.5
Moisture Removal				l/h	2.5	2.5	3.0	3.5
Noise (Indoor)		Cooling	H/M/L/Q	dB(A)	31/29/27/25	42/37/32/29	42/37/32/29	44/38/33/29
Noise (Outdoor)		Cooling		dB(A)	52	53	54	55
Airflow (High)		Indoor/Outdoor		m <sup>3</sup> /h	1100/2470	2100/3600	2100/4000	2250/6600
		Indoor		mm	270x1135x700	270x1135x700	270x1135x700	270x1135x700
Net Dimension H x W x D		Outdoor		mm	578x790x315	830x900x330	830x900x330	1290x900x330
				kg(lbs)	38(84)	40(88)	40(88)	41(90)
Weight				mm	44(97)	62(136)	62(136)	98(216)
				kg(lbs)	44(97)	62(136)	62(136)	98(216)
Piping Connections(Small/Large)				mm	6.35/15.88	9.52/15.88	9.52/15.88	9.52/15.88
Drain Pipe Diameter (Inner/Outer)				mm	36.0/38.0	22.0/25.6	22.0/25.6	36.0/38.0
Max Pipe Length (Chargeless)				m	30	50	50	50
Max Height Difference				m	20	30	30	30
Operation Range		Cooling	°C	-10~46	-15~46	-15~46	-15~46	-15~46
		Heating	°C	-15~24	-15~24	-15~24	-15~24	-15~24
Refrigerant					R410A	R410A	R410A	R410A

The measurement static pressure of ARYA24LA, 45LA is 30 Pa and ARYA30LB, 36LB is 47 Pa.

# INVERTER

## DUCT TYPE (High static pressure)

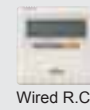

Wired R.C.



ARY45LH ARY54LU

### Design also corresponding to high static pressure

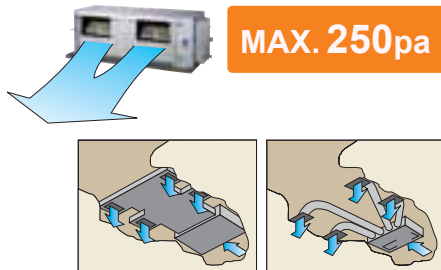

### Easy installation (Compact size & Lightweight)

By downsizing basic chassis and reducing materials weight, compact size and lightweight are realized

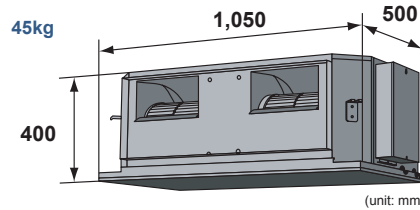

### Low noise

Turbulent air flow is reduced by cutting off the corners of conventional indoor unit front panel and fan case

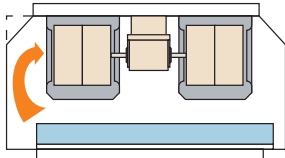

Low noise is realized by adopting plastic case, plastic fan

Plastic fan [45dB(A)]

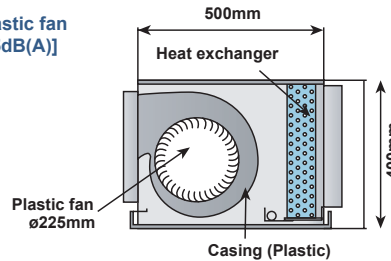

\* Model : Material (At 100Pa : Actual noise measurement value)

### Accurate & Comfortable

- New amenity space can be offered by installing a thermo sensor in the remote controller.
- Because the remote controller has a switching function, the user can select the sensor position. (Room temperature sensor selection)

Example of room temperature sensor selection

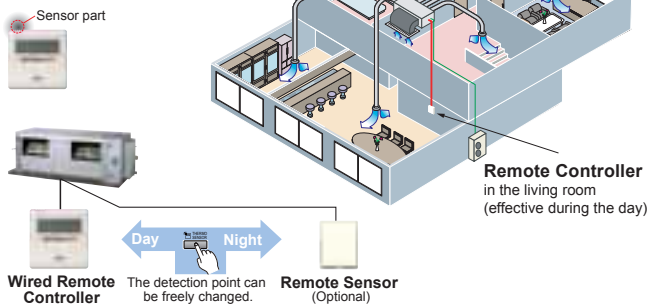

Wired Remote Controller The detection point can be freely changed. Remote Sensor (Optional)

### Optional parts

- Long Life Filter: UTD-LF60KA
- Remote Sensor Unit: UTD-RS100
- External Control Set: UTD-ECS5A
- Simple Remote Controller: UTB-YPB
- IR Receiver Unit: UTY-LRJY1

### SPECIFICATIONS

Reference	Model No.	Indoor Unit		ARY45LH	ARY54LU		
		Outdoor Unit		AOY45LH	AOY54LU		
Input Power		V/ø/Hz		230/1/50	230/1/50		
Capacity		Cooling	kW	12.50	14.00		
		Heating	kW	14.00	16.00		
Power Consumption		Cooling/Heating		kW	4.3/3.8	5.36/4.7	
EER - Energy Class		Cooling		W/W	2.91	2.61	
COP - Energy Class		Heating			3.68	3.40	
Running Current		Cooling/Heating		A	18.9/16.7	23.6/20.6	
Moisture Removal				l/h	3.0	4.0	
Noise (Indoor)		Cooling	H/M/L	dB(A)		49/45/42	49/45/42
Noise (Outdoor)		Cooling				54	54
Airflow (High)		Indoor/Outdoor		m³/h		3500/6600	3500/6600
Net Dimension H x W x D	Indoor			mm		400x1050x500	400x1050x500
				kg(lbs)		50(110)	50(110)
				mm		1,290x900x330	1,290x900x330
Weight	Outdoor			kg(lbs)		105(231)	105(231)
				mm		9.52/15.88	9.52/15.88
Piping Connections(Small/Large)				mm		21.5/25.4	21.5/25.4
Drain Pipe Diameter (Inner/Outer)				m		70	70
Max Pipe Length (Chargeless)						30	30
Max Height Difference							
Operation Range		Cooling	°C			-15~43	-15~43
		Heating				-15~24	-15~24
Refrigerant						R410A	R410A

The measurement static pressure is 100 Pa.

# COMPACT CASSETTE TYPE



## Comfortable air flow

### 4 step swing

Auto air flow direction and auto swing

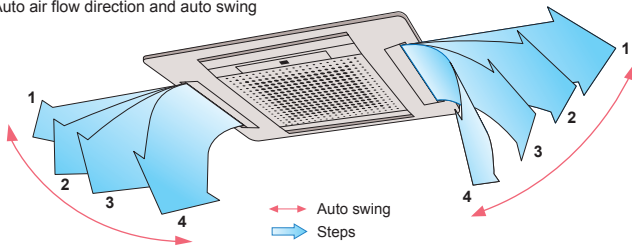

### 2-4 way air flow system

Select 2-way, 3-way or 4-way air flow to suit your needs.

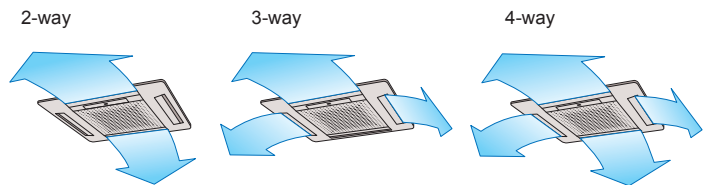

## Compact size

Compact grille fits European ceiling panel (650 x 650 mm)

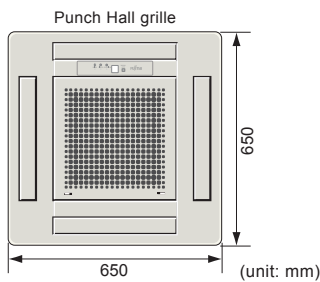

### Condensate pump lift to 400mm

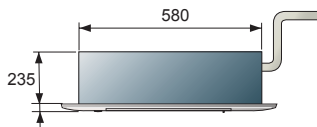

## Duct connection hole opening

Fresh air can be introduced through this opening

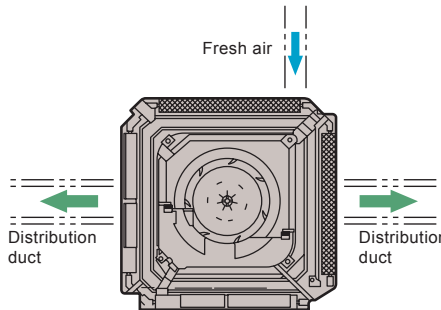

Conditioned air can be distributed by means of a distribution duct

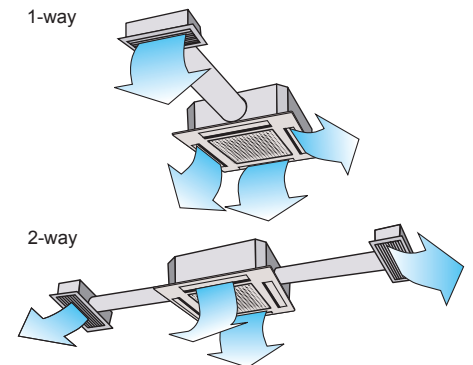

## Additional grille (optional parts)

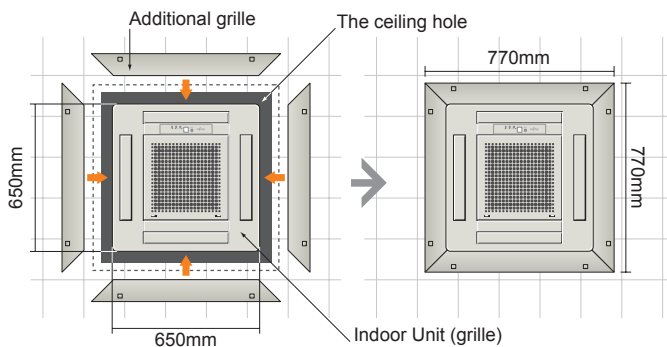

## Optional parts

Additional Grille: UTG-AGDA-W

## SPECIFICATIONS

Reference	Model No.	Indoor Unit			
		AUY12UB	AUY14UB	AUY18UB	
Input Power	Outdoor Unit	AOY12UB	AOY14UB	AOY18UB	
	V/ø/Hz	230/1/50	230/1/50	230/1/50	
Capacity	Cooling	kW	3.55	3.95	4.85
	Heating	kW	4.00	4.60	5.40
Power Consumption	Cooling/Heating	kW	1.24/1.21	1.40/1.42	1.85/2.00
EER - Energy Class	Cooling	W/W	2.86-C	2.82-C	2.62-D
COP - Energy Class	Heating	W/W	3.31-C	3.24-C	2.70-D
Running Current	Cooling/Heating	A	5.5/5.4	6.3/6.3	8.2/9.2
Moisture Removal		l/h	1.3	1.5	2.1
Noise (Indoor)	Cooling H/M/L	dB(A)	42/39/36	42/39/36	44/41/37
Noise (Outdoor)	Cooling	dB(A)	49	49	52
Airflow (High)	Indoor/Outdoor	m³/h	550/1600	550/1600	620/3200
Net Dimension	Indoor	mm	235 x 580 x 580	235 x 580 x 580	235 x 580 x 580
	Outdoor	mm	530 x 750 x 250	530 x 750 x 250	650 x 830 x 320
Weight		kg(lbs)	18(40)	18(40)	18(40)
		kg(lbs)	34(75)	35(77)	52(115)
Piping Connections(Small/Large)		mm	6.35/9.52	6.35/12.7	6.35/12.7
Max Pipe Length (Chargeless)		m	20	20	20
Max Height Difference		m	8	8	8
Operation	Cooling	°C	0~43	0~43	0~43
	Heating	°C	-7~24	-7~24	-7~24
Refrigerant			R410A	R410A	R410A
Grille			UTG-UDYD-W	UTG-UDYD-W	UTG-UDYD-W

# CASSETTE TYPE



## Comfortable air flow

### 4 step swing

Auto air flow direction and auto swing

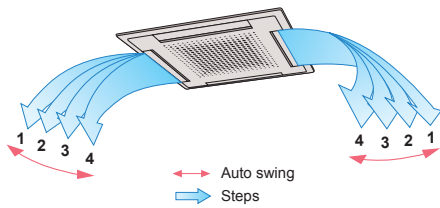

### 2-4 way air flow system

Select 2-way, 3-way or 4-way air flow to suit your needs.

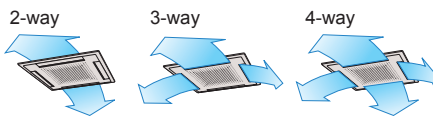

**Wide air flow**  
Larger air flap distributes the outlet air flow a longer distance in the horizontal direction.

## Flexible installation

Installation is done by "Standard setting" with more than 300mm (250mm) of space. "Slender setting" lets it suitable for minimum 265mm (215mm) installation space.

Installation Space (Built-in measurement)

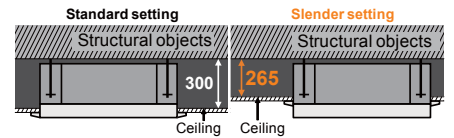

	25UU/30UU	36UU/45UU/54UU
Standard setting	250mm	300mm
Slender setting	215mm	265mm

## Duct connection hole opening

Fresh air can be introduced through this opening

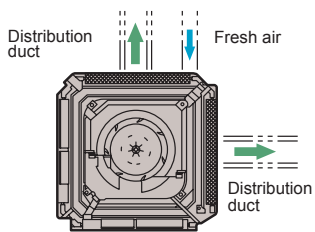

Conditioned air can be distributed by means of a distribution duct

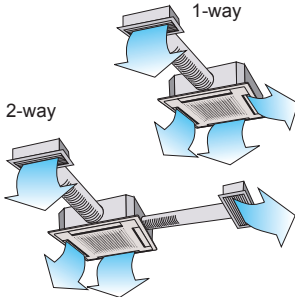

## Easy maintenance

The control box is easily accessible for maintenance work. Wide opening for easy access.

### Detachable, washable filter and intake grille

Wide opening and long-life filter

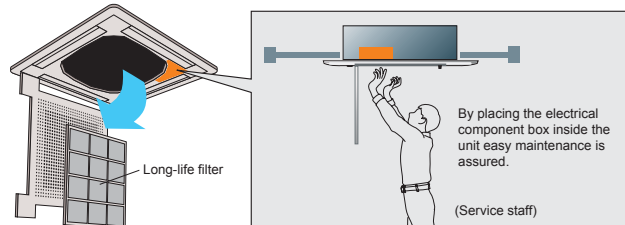

### Long-life filter

High efficiency, long-life filter extends the cleaning cycle.

## Condensate pump lift to 800mm



## Optional parts

Additional Grille: UTG-AGEA-W  
Simple Remote Controller : UTB-YPB



## SPECIFICATIONS

Model No.	Indoor Unit		AUY25UU	AUY30UU	AUY36UU	AUY45UU	AUY54UU
	Outdoor Unit		AOY25UU	AOY30UU	AOY36UU	AOY45UU	AOY54UU
Input Power		V/ø/Hz	230/1/50	230/1/50	400/3/50	400/3/50	400/3/50
Capacity	Cooling	kW	7.00	8.40	10.50	12.70	14.50
	Heating	kW	7.80	9.50	11.80	14.30	16.50
Power Consumption	Cooling/Heating	kW	2.65/2.35	2.95/2.78	3.48/3.65	4.38/4.39	5.16/5.3
EER - Energy Class	Cooling		2.64-D	2.85-C	3.02-B	2.9	2.81
COP - Energy Class	Heating	W/W	3.32-D	3.42-C	3.23-B	3.26	3.11
Running Current	Cooling/Heating	A	11.8/10.5	13.6/13.1	5.9/6.2	7.7/7.7	9.5/9.5
Moisture Removal		l/h	2.5	3.0	4.0	5.0	6.0
Noise (Indoor)	Cooling / H/M/L	dB(A)	44/42/39	46/44/39	48/44/41	49/47/43	52/48/45
Noise (Outdoor)	Cooling	dB(A)	53	53	54	54	54
Airflow (High)	Indoor/Outdoor	m³/h	1100/3200	1250/3300	1500/6100	1550/6100	1700/6300
Net Dimension H x W x D	Indoor	mm	246x830x830	246x830x830	296x830x830	296x830x830	296x830x830
		kg(lbs)	34(75)	34(75)	37(82)	40(88)	40(88)
		mm	650x830x320	830x900x330	1165x900x330	1165x900x330	1290x900x330
Weight	Outdoor	kg(lbs)	59(130)	69(152)	94(207)	113(249)	118(260)
		mm	9.52/15.88	9.52/15.88	9.52/15.88	9.52/19.05	9.52/19.05
Piping Connections(Small/Large)		mm	9.52/15.88	9.52/15.88	9.52/15.88	9.52/19.05	9.52/19.05
Max Pipe Length (Chargeless)		m	25	30	50	50	50
Max Height Difference		m	15	15	30	30	30
Operation Range	Cooling	°C	0~43	0~43	0~43	0~43	0~43
	Heating	°C	-7~24	-7~24	-7~24	-7~24	-10~24
Refrigerant			R410A	R410A	R410A	R410A	R410A

# FLOOR/CEILING UNIVERSAL TYPE



## Flexible installation

### Example for floor installation

Floor console



### Example for ceiling installation

Under ceiling



## Double auto swing

A combination of up/down and right/left directional swing allows three-dimensional air direction control

Right and Left Swing

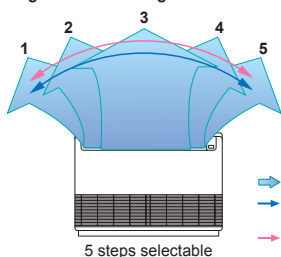

5 steps selectable

Up and Down Swing

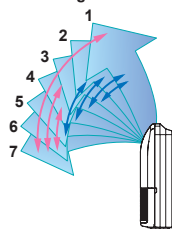

7 steps selectable

Steps  
 → Swing : Cooling, Dry and Fan mode  
 → Swing : Heating and Fan mode

## Compact design

Symmetrical, slim and compact design

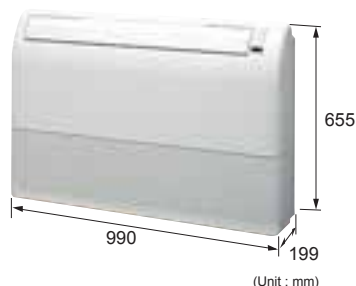

(Unit : mm)



## Super vane

Double-flap "Super Vane" with newly developed special configuration boosts air flow sending cool air quickly to every corner of the room

## Auto-closing louvre

This function is common to all indoor unit types except the duct type

## SPECIFICATIONS

Model No.	Indoor Unit		ABY14UB	ABY18UB	ABY24UB
Reference	Outdoor Unit		AOY14UB	AOY18UB	AOY24UB
Input Power	V/φ/Hz		230/1/50	230/1/50	230/1/50
Capacity	Cooling	kW	4.00	5.40	6.50
	Heating	kW	4.70	6.00	7.40
Power Consumption	Cooling/Heating	kW	1.42/1.35	1.90/1.85	2.42/2.30
EER - Energy Class	Cooling		2.82-C	2.84-C	2.69-D
COP - Energy Class	Heating	W/W	3.48-C	3.24-C	3.22-D
Running Current	Cooling/Heating	A	6.3/6.0	8.6/8.3	10.8/10.3
Moisture Removal		l/h	1.5	2.0	2.5
Noise (Indoor)	Cooling	H/M/L	41/38/35	47/42.5/38	50/46/42
Noise (Outdoor)	Cooling		49	52	53
Airflow (High)	Indoor/Outdoor	m <sup>3</sup> /h	640/1600	780/3200	880/3200
Net Dimension H x W x D	Indoor	mm	199x990x655	199x990x655	199x990x655
		kg(lbs)	28(62)	28(62)	28(62)
Weight	Outdoor	mm	530x750x250	650x830x320	650x830x320
		kg(lbs)	35(77)	52(115)	59(131)
Piping Connections(Small/Large)		mm	6.35/12.7	6.35/15.88	9.52/15.88
Max Pipe Length (Chargeless)		m	15	20	20
Max Height Difference			8	8	8
Operation Range	Cooling	°C	0~43	0~43	0~43
	Heating		-6~24	-6~24	-6~24
Refrigerant			R410A	R410A	R410A



# CEILING TYPE



## Installation

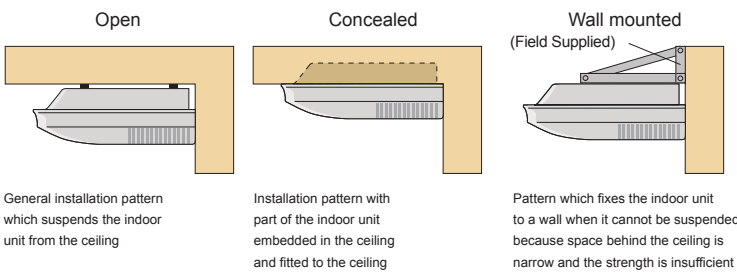

## Thin & slender form

### Thin and Slender



## Double auto swing

### Auto air flow direction and auto swing

#### Right and Left Swing

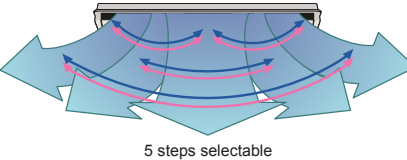

#### Up and Down Swing

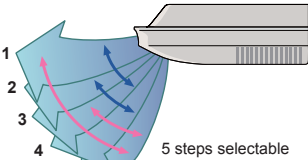

- Steps
- Swing : Cooling and Dry mode
- Swing : Heating and Fan mode

## Long-life filter

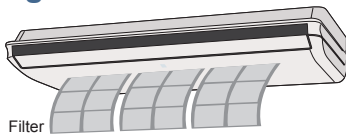

## Fresh air intake

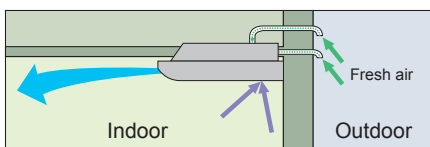

## Drain water lift-up mechanism (Optional)

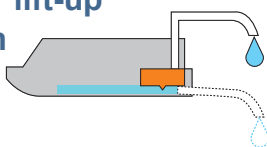

## Optional parts

- Flange (Round): UTD-RF204
- Drain Pump Unit: UTR-DPB24T

## SPECIFICATIONS

Model No.	Indoor Unit		ABY30UB	ABY36UB	ABY45UB	ABY54UB
	Reference	Outdoor Unit	AOY30UB	AOY36UB	AOY45UB	AOY54UB
Input Power		V/ø/Hz	230/1/50	400/3/50	400/3/50	400/3/50
Capacity	Cooling	kW	8.40	10.50	12.70	14.50
	Heating		9.50	11.80	14.30	16.50
Power Consumption	Cooling/Heating	kW	2.95/2.78	3.48/3.45	4.38/4.39	5.16/5.30
EER - Energy Class	Cooling		2.85-C	3.02-B	2.90	2.81
COP - Energy Class	Heating	W/W	3.42-C	3.42-B	3.26	3.11
Running Current	Cooling/Heating	A	13.6/13.1	5.9/6.2	7.7/7.7	9.5/9.5
Moisture Removal		l/h	3.0	4.0	5.0	6.0
Noise (Indoor)	Cooling   H/M/L	dB(A)	42/39/35	45/42/37	48/46/41	52/50/46
Noise (Outdoor)	Cooling		53	54	54	54
Airflow (High)	Indoor/Outdoor	m³/h	1450/3300	1660/6100	1850/6100	2200/6300
Net Dimension H x W x D	Indoor	mm	240x1660x700	240x1660x700	240x1660x700	240x1660x700
		kg(lbs)	48(106)	48(106)	48(106)	48(106)
Weight	Outdoor	mm	830x900x330	1165x900x330	1165x900x330	1290x900x330
		kg(lbs)	69(152)	94(207)	113(249)	118(260)
Piping Connections(Small/Large)		mm	9.52/15.88	9.52/15.88	9.52/19.05	9.52/19.05
Max Pipe Length (Chargeless)		m	30	50	50	50
Max Height Difference			15	30	30	30
Operation	Cooling	°C	0~43	0~43	0~43	0~43
Range	Heating		-7~24	-10~24	-10~24	-10~24
Refrigerant			R410A	R410A	R410A	R410A

# COMPACT DUCT TYPE



## Flexible installation

Ceiling concealed

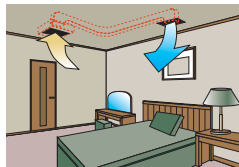
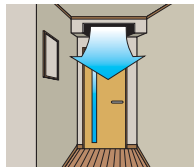

Floor concealed

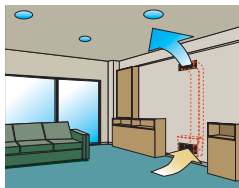
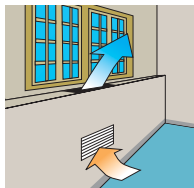

## Air-intake

Air intake direction can be selected to match the installation site

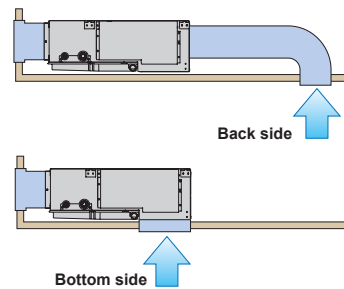

## Optional function for comfort

Optional parts

IR receiver unit

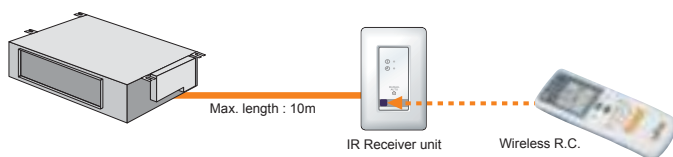

## Filter

ARY7UU/9UU

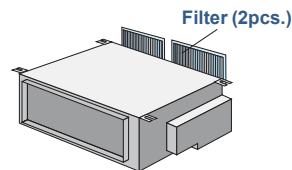

ARY12UU/14UU/18UU

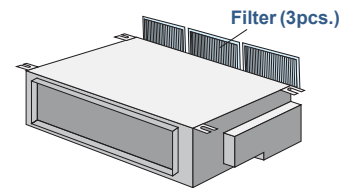

## Optional parts

Remote Sensor Unit: UTD-RS100

Simple Remote Controller: UTB-YPB

Drain Pump Unit: UTZ-PX1BBA

IR Receiver Unit: UTY-LRHY1



## SPECIFICATIONS

Model No.	Indoor Unit		ARY7UU	ARY9UU	ARY12UU	ARY14UU	ARY18UU
Reference	Outdoor Unit		AOY7UU	AOY9UU	AOY12UU	AOY14UU	AOY18UU
Input Power	V/ø/Hz		230/1/50	230/1/50	230/1/50	230/1/50	230/1/50
Capacity	Cooling	kW	2.15	2.70	3.50	4.00	5.40
	Heating	kW	2.45	3.10	4.00	4.70	6.00
Power Consumption	Cooling/Heating	kW	0.76/0.76	0.96/0.96	1.24/1.21	1.42/1.35	1.92/1.87
EER - Energy Class	Cooling	W/W	2.83-C	2.81-C	2.82-C	2.82-C	2.81-C
COP - Energy Class	Heating	W/W	3.22-C	3.23-C	3.31-C	3.48-C	3.21-C
Running Current	Cooling/Heating	A	3.6/3.6	4.4/4.5	5.5/5.4	6.3/6.0	8.8/8.7
Moisture Removal		l/h	0.8	1.0	1.2	1.5	1.6
Noise (Indoor)	Cooling	H/M/L	31/28/26	35/33/31	29/28/27	34/32/30	43/40/36
Noise (Outdoor)	Cooling		48	48	49	49	52
Airflow (High)	Indoor/Outdoor	m³/h	340/1600	420/1600	500/1600	640/1600	1000/3200
Net Dimension H x W x D	Indoor	mm	217x663x595	217x663x595	217x953x595	217x953x595	217x953x595
		kg(lbs)	18(40)	18(40)	25(55)	25(55)	25(55)
Weight	Outdoor	mm	530x750x250	530x750x250	530x750x250	530x750x250	650x830x320
		kg(lbs)	28(62)	30(66)	34(75)	35(77)	52(115)
Piping Connections(Small/Large)		mm	6.35/9.52	6.35/9.52	6.35/9.52	6.35/12.70	6.35/15.88
Max Pipe Length (Chargeless)		m	15	15	15	15	20
Max Height Difference			8	8	8	8	8
Operation	Cooling	°C	0~43	0~43	0~43	0~43	0~43
Range	Heating	°C	-6~24	-6~24	-6~24	-6~24	-6~24
Refrigerant			R410A	R410A	R410A	R410A	R410A

The measurement static pressure is 0 Pa.

# DUCT TYPE



## Installation styles

### Embedded in Ceiling

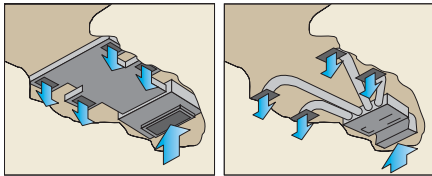

### Hanging from Ceiling

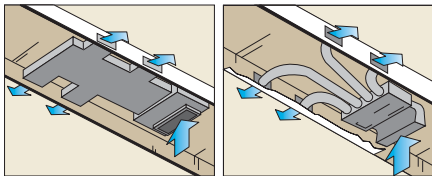

## Slim & Compact design

In the case of bottom suction type, not only does the design allow for installation in narrow ceiling space up to 270mm, further space requirements have been guaranteed by placing the control box inside the chassis.

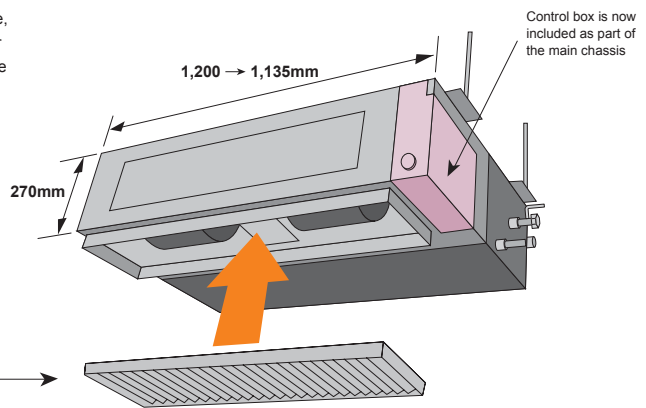

## Easy maintenance

### In the case of rear suction type, as seen from lower rear part

Structural improvement is attained by making the bottom panel two pieces, front and rear, and the internal fan casing is also made dismantlable in two pieces, namely, upper and lower ones. The motor and fan maintenance and dismantling can be made easily by removing the rear panel and lower part of the casing with the main chassis installed.

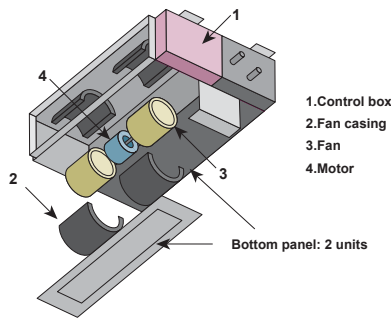

## 2-direction drain piping

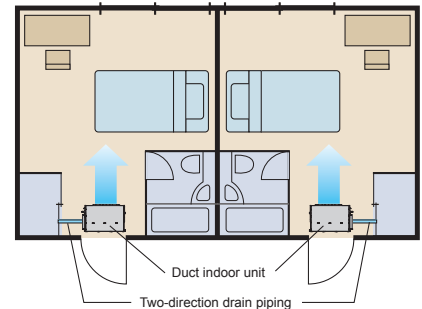

## Optional parts

- Remote Sensor Unit: UTD-RS100
- External Control Set: UTD-ECS5A
- Simple Remote Controller: UTB-YPB
- Drain Pump Unit: UTZ-PX1NBA
- IR Receiver Unit: UTY-LRJY1

## SPECIFICATIONS

Model No.	Indoor Unit		ARY25UU	ARY30UU	ARY36U(1)	ARY36UU	ARY45UU
	Outdoor Unit		AOY25UU	AOY30UU	AOY36U(1)	AOY36UU	AOY45UU
Input Power		V/ø/Hz	230/1/50	230/1/50	230/1/50	400/3/50	400/3/50
Capacity	Cooling	kW	7.00	8.40	10.50	10.50	12.70
	Heating	kW	7.70	9.50	12.70	12.70	14.30
Power Consumption	Cooling/Heating	kW	2.65/2.33	2.99/2.63	3.60/3.65	3.6/3.65	4.38/4.39
EER - Energy Class	Cooling		2.64-D	2.81-C	2.92-C	2.92-C	2.9
COP - Energy Class	Heating		3.30-D	3.61-C	3.48-C	3.48-C	3.26
Running Current	Cooling/Heating	A	11.8/10.5	14.0/12.4	16.0/16.5	6.1/6.2	7.7/7.7
Moisture Removal		l/h	2.5	3.0	3.5	3.5	5.0
Noise (Indoor)	Cooling	H/M/L	38/36/34	40/38/36	43/41/39	43/41/39	44/42/40
Noise (Outdoor)	Cooling		53	53	54	54	54
Airflow (High)	Indoor/Outdoor	m³/h	1100/3200	1400/3300	1750/6100	1750/6100	1800/6100
Net Dimension H x W x D	Indoor	mm	270x1135x700	270x1135x700	270x1135x700	270x1135x700	270x1135x700
		kg(lbs)	43(95)	43(95)	43(95)	43(95)	45(99)
Weight	Outdoor	mm	650 x 830 x 320	830x900x330	1165x900x330	1165x900x330	1165x900x330
		kg(lbs)	59(130)	69(152)	98(216)	94(207)	113(249)
Piping Connections(Small/Large)		mm	9.52-15.88	9.52-15.88	9.52-15.88	9.52-15.88	9.52-19.05
Max Pipe Length (Chargeless)		m	25	30	50	50	50
Max Height Difference		m	15	15	30	30	30
Operation Range	Cooling	°C	0~43	0~43	0~43	0~43	0~43
	Heating	°C	-7~24	-7~24	-10~24	-10~24	-10~24
Refrigerant			R410A	R410A	R410A	R410A	R410A

The measurement static pressure is 100 Pa.

# DUCT TYPE (High static pressure)



## Design also corresponding to high static pressure

Model: ARY90TL

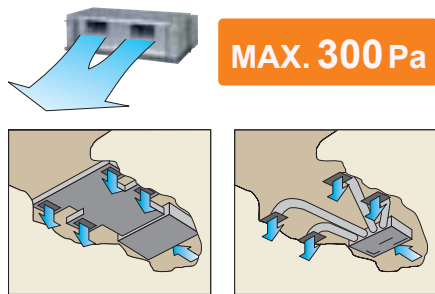

## Low noise

Turbulent air flow is reduced by cutting off the corners of conventional indoor unit front panel and fan case

Low noise is realized by adopting plastic case, plastic fan.

Plastic fan [45dB(A)] (ARY60UU)

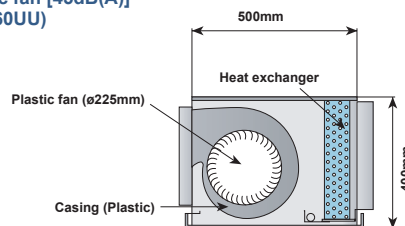

(ARY60UU)

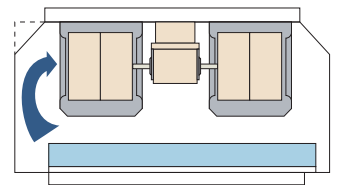

\* Model : Material (At 100Pa : Actual noise measurement value)

## Pursuance of amenity performance

Various remote controllers and sensors can be selected

### 1.Wired Remote Controller with Thermo Sensor

- Room temperature sensor selection
- WEEKLY timer
- Temperature SET BACK timer
- Group control system
- Child lock
- Dual remote controllers <Optional parts>
- AUTO restart
- Energy saving
- Auto changeover <for heating>
- Hot start <for heating>

### 2.Simple Remote Controller (Optional Parts)

### 3.Remote Sensor (Optional Parts)



## Accurate & Comfortable

- New amenity space can be offered by installing a thermo sensor in the remote controller.
- Because the remote controller has a switching function, the user can select the sensor position. (Room temperature sensor selection)

Example of room temperature sensor selection

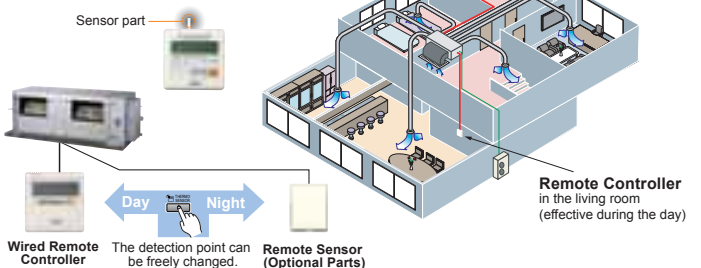

## SPECIFICATIONS

Model No. Reference	Indoor Unit		ARY60UU	ARY90TL
	Outdoor Unit		AOY60UU	AOY90TL
Input Power	V/ø/Hz		400/3/50	380-415/3/50
Capacity	Cooling	kW	16.50	24.80-25.40
	Heating		19.50	28.90-29.50
Power Consumption	Cooling/Heating	kW	6.06/5.54	12.2-12.5/12.2-12.5
EER - Energy Class	Cooling		2.72	2.03-2.03
COP - Energy Class	Heating	W/W	3.52	2.37-2.36
Running Current	Cooling/Heating	A	10.2/9.8	19.5/19.5
Moisture Removal		l/h	4.0	7.5
Noise (Indoor)	Cooling	H/M/L	49/45/42	50.5
Noise (Outdoor)	Cooling		54	59
Airflow (High)	Indoor/Outdoor	m³/h	3500/6300	4300/9800
Net Dimension H x W x D	Indoor	mm	400x1050x500	450x1,550x700
		kg(lbs)	50(110)	85(187)
Weight	Outdoor	mm	1290x900x330	1,380x1,300x650
		kg(lbs)	118(260)	245(540)
Piping Connections(Small/Large)		mm	9.52-19.05	12.70-28.58
Max Pipe Length (Chargeless)		m	50	50
Max Height Difference			30	30
Operation Range	Cooling	°C	0~43	0~46
	Heating		-10~24	-10~21
Refrigerant			R410A	R407C

The measurement static pressure of ARY60UU is 100Pa and ARY90TL is 196Pa.

## Optional parts

Long-Life Filter: UTD-LF60KA (For ARY60UU)

IR Receiver Unit: UTY-LRJY1(For ARY60UU)

Simple Remote Controller: UTB-YPB

Remote Sensor Unit: UTD-RS100

External Control Set: UTD-ECS5A(For ARY60UU)

# MULTI TYPE SYSTEMS (2 rooms)

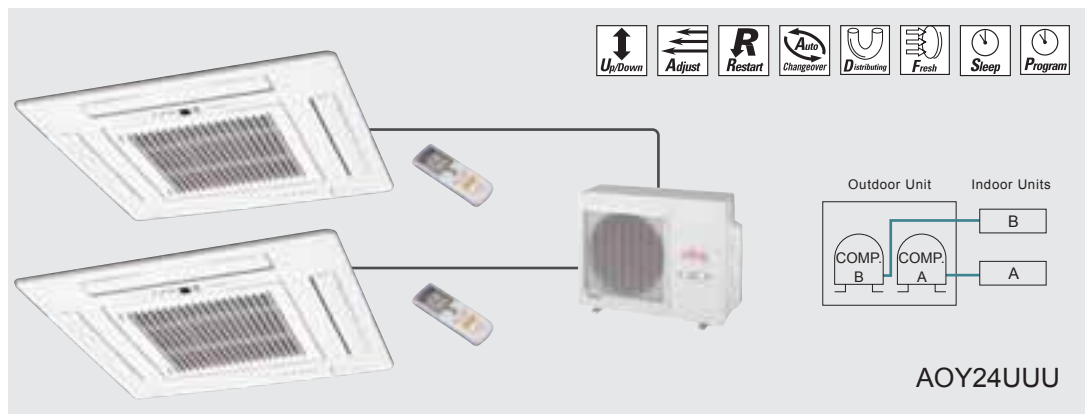
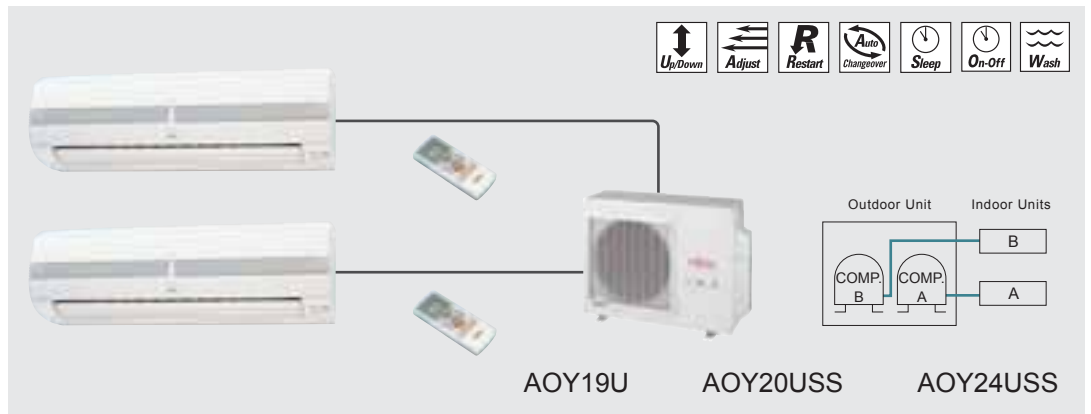
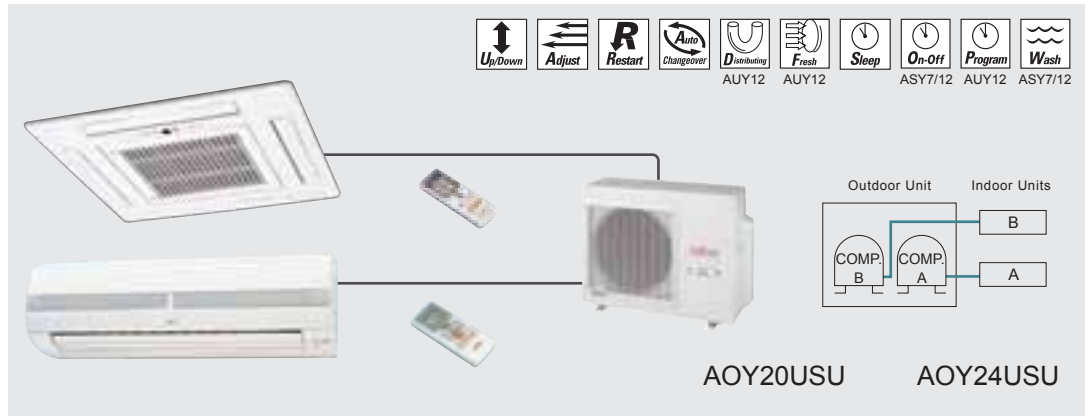

## SPECIFICATIONS

Model No.	Indoor Unit	AS9Y9UMB	AS9Y9UMBx2	AS12Y12UMA AS7Y7UMA	AS12Y12UMA + AS7Y7UMA	AS12Y12UMB	AS12Y12UMBx2	AS12Y12UMB AUY12UMA	AS12Y12UMA + AUY12UMA	AUY12UMA	AUY12UMAx2	
Reference	Outdoor Unit	AOY19USCV2		AOY20USBV2		AOY24USBV2		AOY24USBV2		AOY24USBV2		
Input Power	V/φ/Hz	230/1/50		230/1/50		230/1/50		230/1/50		230/1/50		
Capacity	Cooling	2.85	5.60	3.45,2.25	5.70	3.50	7.00	3.5/3.50	7.00	3.50	7.00	
	Heating	3.25	6.50	4.00,2.70	6.70	4.10	8.20	4.10/4.10	8.20	4.10	8.20	
Power Consumption	Cooling/Heating	0.99/1.03	1.86/1.9	1.30,86,1.38/0.95	2.03 / 2.15	1.3/1.38	2.55/2.55	1.30/1.38	2.55	1.3/1.38	2.55	
EER - Energy Class	Cooling	W/W	-	3.01-B	-	2.81-C	-	2.75-D	-	2.75-D	-	2.75-D
COP - Energy Class	Heating	A	-	3.42-B	-	3.12-C	-	3.22-D	-	3.22-D	-	3.22-D
Running Current	Cooling/Heating	l/h	4.6/4.6	8.6/8.6	5.8/4.1,6.1/4.3	9.2/9.7	5.8/6.1	11.2/11.4	5.8/6.1	11.2/11.4	5.8/6.1	11.2/11.4
Moisture Removal		l/h	1.0	2.0	1.3,1.0	2.3	1.3	2.6	1.3	2.6	1.3	2.6
Noise (Indoor)	Cooling	H/M/L	36/34/29	-	38/37/35,36/33/31	-	38/37/33	-	38/37/33, 42/39/36	-	42/39/36	-
Noise (Outdoor)	Cooling		51		52		52		52		52	
Airflow (High)	Indoor/Outdoor	m <sup>3</sup> /h	470/3200	470x2/3200	520,420/3000	520+420/3000	520/3200	520x2/3200	520,550/3200	520+550/3200	550/3200	550x2/3200
Net Dimension H x W x D	Indoor	kg(lbs)	257x808x187	257x808x187	257x808x187	-	257x808x187	-	257x808x187/235x580x580(+70)	-	235x580x580(+70)	-
	Outdoor	mm	700x900x330	700x900x330	700x900x330	700x900x330	700x900x330	700x900x330	700x900x330	700x900x330	700x900x330	
Weight		kg(lbs)	63(139)	66(146)	63(139)	66(146)	70(154)	70(154)	70(154)	70(154)	70(154)	
Piping Connections(Small/Large)		mm	6.35/9.52	6.35/9.52	6.35/9.52	6.35/9.52	6.35/9.52	6.35/9.52	6.35/9.52	6.35/9.52	6.35/9.52	
Max Pipe Length (Chargeless)		m	15 + 15	15 + 15	15 + 15	15 + 15	15 + 15	15 + 15	15 + 15	15 + 15	15 + 15	
Max Height Difference		m	8	8	8	8	8	8	8	8	8	
Operation Range	Cooling	°C	10~43	10~43	10~43	18~43	18~43	18~43	18~43	18~43	18~43	
	Heating	°C	-5~24	-5~24	-5~24	-5~43	-5~43	-5~43	-5~43	-5~43	-5~43	
Refrigerant			R410A	R410A	R410A	R410A	R410A	R410A	R410A	R410A	R410A	

# BIG MULTI TYPE SYSTEMS

## Simultaneous Operation

### Features of System Operations

- Simultaneous Operating System suitable for large spaces such as offices, lobbies and waiting rooms of high-rise buildings.
- One controller can simultaneously control cooling or heating by 2~4 indoor units.

- Long piping for high-rise buildings
- Various combinations of indoor unit types and capacities
- Centralized control by wired remote controller with weekly timer
- Cooling and heating at low outdoor temperatures
- Space saving
- Easy installation

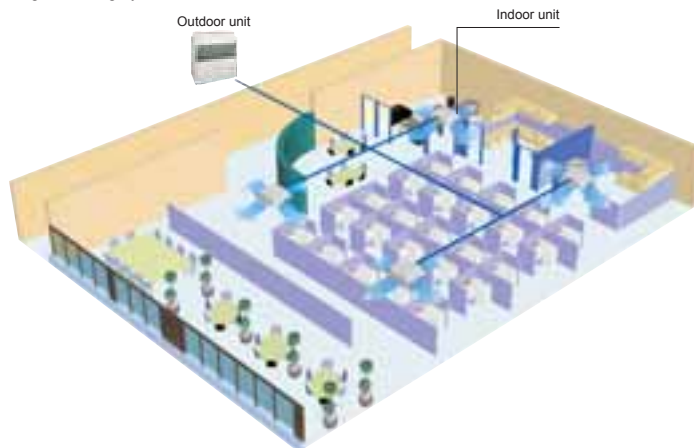

### Indoor Unit Combinations

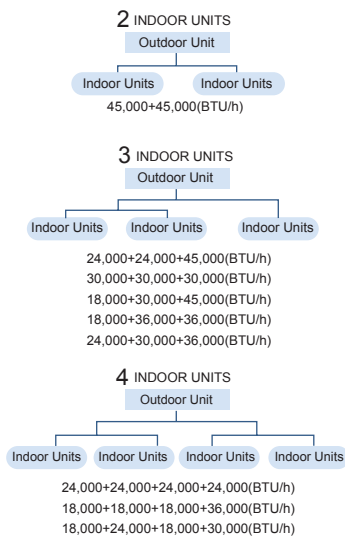

### Indoor Unit Lineup

CAPACITY (BTU)	CASSETTE (COMPACT)	CASSETTE	DUCT	FLOOR/CEILING UNIVERSAL	CEILING(LARGE)
	45,000		•	•	
36,000		•	•		•
30,000		•	•		•
(25,000)		•	•		•
24,000				•	
18,000	•			•	

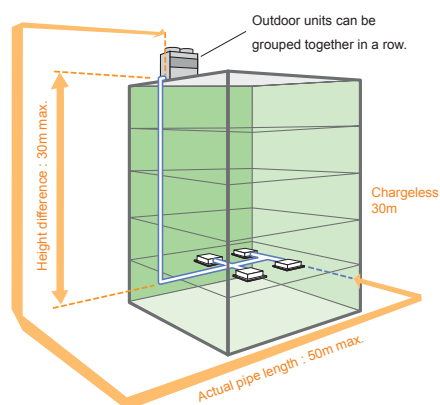

### Refrigerant System

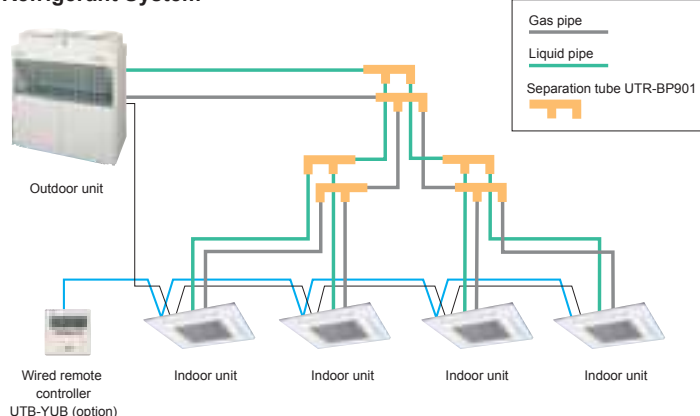

### SPECIFICATIONS

Reference	Model No.	ABYA18TATA	ABYA24TATA	ABYA30TATA	ABYA36TATA	ABYA45TATA	ARXA25TATA	ARXA30TATA	ARXA36TATA	ARXA45TATA	
Input Power	V/ø/Hz	220~240/1/50	220~240/1/50	220~240/1/50	220~240/1/50	220~240/1/50	220~240/1/50	220~240/1/50	220~240/1/50	220~240/1/50	
Capacity	Cooling	kW	5.20~5.30	6.50~6.60	8.60~8.80	10.30~10.50	12.40~12.70	6.95~7.05	8.60~8.80	10.30~10.50	12.40~12.70
		Heating	5.50~5.60	7.60~7.70	8.80~9.10	10.50~10.70	13.40~13.70	7.60~7.85	8.80~9.10	10.50~10.70	13.40~13.70
	Cooling	BTU/h	17,800~18,100	22,200~22,500	29,400~30,000	35,200~36,000	42,500~43,500	23,700~24,100	29,400~30,000	35,200~36,000	42,500~43,500
		Heating	18,800~19,100	25,900~26,300	30,000~31,000	36,000~36,500	46,000~47,000	25,900~26,800	30,000~31,000	36,000~36,500	46,000~47,000
Moisture Removal	l/h	2.20	3.40	4.00	4.00	5.50	2.50	3.00	4.00	5.50	
Room Air Circulation	High	800	900	1,270	1,660	1,850	1,600	1,650	2,000	2,200	
	Med	680	780	1,120	1,500	1,660	1,450	1,550	1,800	2,000	
	Low	560	660	860	1,270	1,430	1,280	1,350	1,600	1,800	
Fan Motor Output	W	30	40	160	160	160	70	275	275	275	
Fan Type x Qty		Sirocco x 2	Sirocco x 2	Sirocco x 4	Sirocco x 4	Sirocco x 4	Sirocco x 2	Sirocco x 2	Sirocco x 2	Sirocco x 2	
Net Dimension H x W x D	mm	199x990x655	199x990x655	240x1,660x700	240x1,660x700	240x1,660x700	270x1,210x700	270x1,210x700	270x1,210x700	270x1,210x700	
	kg	28	30	48	48	48	43	43	45	45	
Connection Method		Flare	Flare	Flare	Flare	Flare	Flare	Flare	Flare	Flare	
Connection Pipe Size (Smallø/Largeø)	mm	9.53/15.88	9.53/15.88	9.53/15.88	9.53/19.05	9.53/19.05	9.53/15.88	9.53/15.88	9.53/19.05	9.53/19.05	
Operation Range	Cooling	18~30	18~30	18~30	18~30	18~30	18~30	18~30	18~30	18~30	
	Heating	16~30	16~30	16~30	16~30	16~30	16~30	16~30	16~30	16~30	
Grille		-	-	-	-	-	-	-	-	-	

# Individual Operation

## Features of System Operations

- Individual Operating System is suitable for large spaces such as hotels, commercial spaces, offices and restaurants.
- The system can cool and heat individually, because it has two refrigeration cycles.

- Two refrigeration cycles
- Various combinations of indoor unit types and capacities
- Centralized control by wired remote controller with weekly timer
- Cooling and heating at low outdoor temperatures
- Space saving
- Easy installation

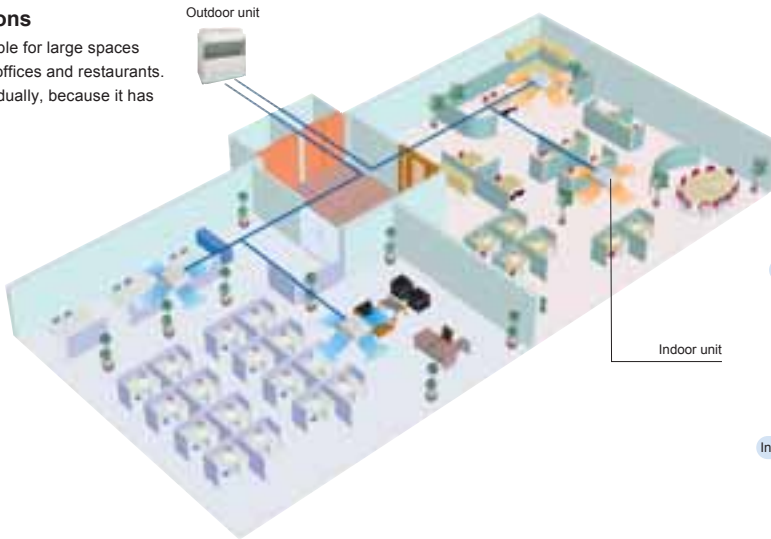

## Indoor Unit Combinations

1 INDOOR UNIT + 1 INDOOR UNIT

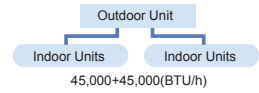

1 INDOOR UNIT + 2 INDOOR UNITS

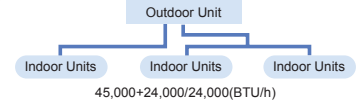

2 INDOOR UNITS + 2 INDOOR UNITS

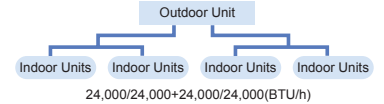

## Indoor Unit Lineup

CAPACITY (BTU)	CASSETTE (COMPACT)	CASSETTE	DUCT	FLOOR/CEILING UNIVERSAL	CEILING(LARGE)
	45,000				
30,000		•	•		•
(25,000)		•	•		•
24,000		•	•	•	•
18,000	•			•	

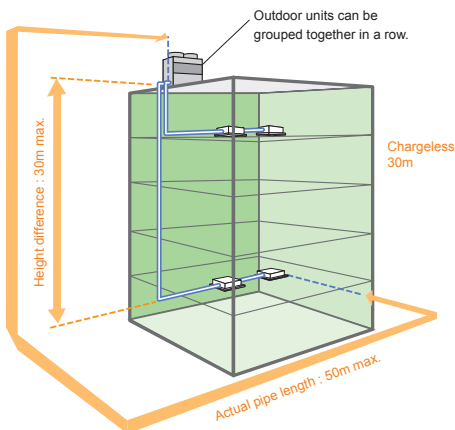

## Refrigerant System

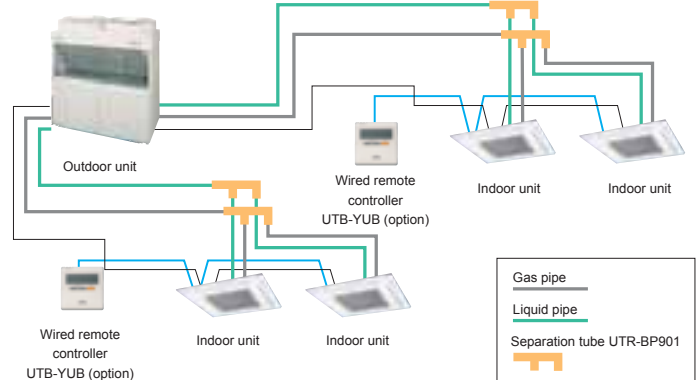

AUXA18TATA	AUYA25TATA	AUYA30TATA	AUYA36TATA	AUYA45TATA
220~240/1/50	220~240/1/50	220~240/1/50	220~240/1/50	220~240/1/50
4.85~5.00	6.95~7.05	8.60~8.80	10.30~10.50	12.40~12.70
5.30~5.45	7.60~7.85	8.80~9.10	10.50~10.70	13.40~13.70
19,000~19,900	23,700~24,100	29,400~30,000	35,200~36,000	42,300~43,400
21,000~21,600	25,900~26,800	30,000~31,100	35,800~36,500	45,800~46,800
2.10	2.50	3.00	4.00	5.00
650	1,170	1,270	1,500	1,650
550	970	1,070	1,300	1,450
490	770	880	1,100	1,200
14	90	90	90	90
Turbo x 1	Turbo x 1	Turbo x 1	Turbo x 1	Turbo x 1
235x580x580(+70)	296x830x830	296x830x830	296x830x830	296x830x830
18	38	38	40	40
Flare	Flare	Flare	Flare	Flare
9.53/15.88	9.53/15.88	9.53/15.88	9.53/19.05	9.53/19.05
18~30	18~30	18~30	18~30	18~30
16~30	16~30	16~30	16~30	16~30
UTG-UDYD-W	-	-	-	-

## SPECIFICATIONS

			Individual Operation		Simultaneous Operation	
			AJYA90EATA	AJYA90TATA	AJYA90EATB	AJYA90TATB
			380~415/W4/50	380~415/W4/50	380~415/W4/50	380~415/W4/50
Power Requirement			V/a/Hz			
Total Capacity	Cooling	kW	25.40	25.40	25.40	25.40
	Heating		-	28.60	-	28.60
Total Input Watts	Cooling	kW	9.40	9.40	9.40	9.40
	Heating		-	10.00	-	10.00
Total Ampacity	Cooling	A	16.20	16.20	16.20	16.20
	Heating		-	17.00	-	17.00
Starting Current			A			
EER	Cooling	W/W	2.70	2.70	2.70	2.70
COP	Heating		-	2.86	-	2.86
Fan Speed	High	r.p.m	730	730	730	730
	Low		360	360	360	360
Air Circulation	High	m³/h	9,800	9,800	9,800	9,800
Fan Type x Q'ty			Propeller x 2	Propeller x 2	Propeller x 2	Propeller x 2
Fan Motor Output			W			
Net Dimension H x W x D			mm			
Weight			kg			
Noise Level(Sound Pressure)			db(A)			
Condition	Indoor Air Temp.	Cooling	27/19	27/19	27/19	27/19
		Heating	20/(15)	20/(15)	20/(15)	20/(15)
	Outdoor Air Temp.	Cooling	35/24	35/24	35/24	35/24
		Heating	7/6	7/6	7/6	7/6
Refrigerant	Type	R407C				
	Charge	kg				
Pipe	Size	Liquid/Gas	3.1x2	3.1x2	6.00	6.00
		mm	9.53/19.05	9.53/19.05	12.70/28.58	12.70/28.58
	Max Length	m	50			
			30			
Max Chargeless Length		30				
Operation(Outdoor)	Cooling	°C	0~52	0~52	0~52	0~52
	Heating		-10~21	-10~21	-10~21	-10~21

# WINDOW TYPE



AKY9UB



AMY12UA



AFY16UA



## The airflow direction can be freely adjusted

Unrestricted direction of airflow.  
The louver allows airflow coverage as wide as 140°.

Mounting the louver in the center provides coverage of an area as wide as 140°. Cold or warm air is distributed throughout the room.

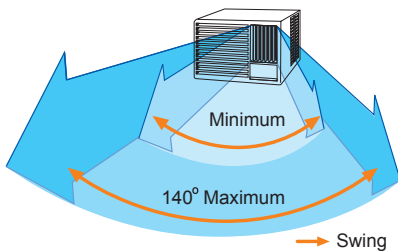

## Easy filter cleaning

The filter can be cleaned without removing the front panel.

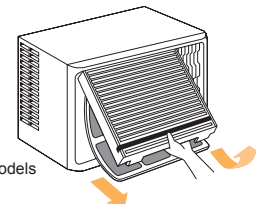

For AFY Models

## SPECIFICATIONS

Model No.		Unit	AKY9UB	AMY12UA	AFY16UA
Input Power		V/ø/Hz	230/1/50	230/1/50	230/1/50
Capacity	Cooling	kW	2.80	3.45	4.55
	Heating		2.90	3.60	4.30
Power Consumption	Cooling/Heating	kW	1.05/0.93	1.40/1.30	1.81/1.62
EER - Energy Class	Cooling	W/W	2.67 - C	2.46 - D	2.51 - D
	Heating		3.12 - C	2.77 - D	2.65 - D
Running Current	Cooling/Heating	A	4.7/4.2	6.2/5.8	8.0/7.2
Moisture Removal		l / h	0.9	1.1	2.1
Noise	Cooling	dB(A)	50.5/41.5	52/48	56.5/51.5
	H/L		350	530	620
Airflow (High)		m <sup>3</sup> /h	350	530	620
Net Dimension H x W x D		mm	349x457x581	375x560x650	400x660x633
Weight		kg(lbs)	33(73)	45(99)	61(134)
	Operation		21~43	21~43	21~43
Range	Cooling	°C	21~43	21~43	21~43
	Heating		0~21	0~21	0~21
Refrigerant			R410A	R410A	R410A
Feature	Super Power		●	●	●
	Super Quiet		●	●	●
	Super Wave		●	●	●
	Instant Air Exchange		●	●	●
	Instant Air Exchange		●	●	●
	Washable Panel		●	●	●



# Explanation of Features

Comfortable Function		Convenient Function		Clean Function	
<b>Up/Down Swing Flaps</b> The up/down flaps automatically swing up and down.	<b>Connectable Distributing Duct</b>	<b>Sleep Timer</b> The micro-computer gradually changes the room temperature automatically to afford a comfortable night's sleep.	<b>Automatic Filter</b> The filter is automatically cleaned after a set amount of time of air conditioner operation.	<b>UV Filter Cleaner</b> UV (ultraviolet rays) suppresses the growth of mold and germs inside the indoor unit.	<b>Plasma Air Cleaner</b> Electrically charged filter removes contaminants, dusts and odors. It also prevents the growth of bacteria.
<b>Double Swing Automatic</b> Complex swing action of flaps enables automatically to swing both horizontal and vertical directions.	<b>Connectable Fresh Air Duct</b>	<b>ON-OFF Timer</b> ON-OFF timer can be set to operate once.	<b>Program Timer</b> This digital timer allows selection of one of four options: ON, OFF, ON→OFF or OFF→ON.	<b>Long-life Ion Deodorization Filter</b> For details, see page 11.	<b>Apple-catechin Filter</b> For details, see page 11.
<b>Automatic Air Flow Adjustment</b> The micro-computer automatically adjusts the air flow effectively to follow the changes of room temperature.	<b>Fresh Air Intake</b> Fresh air can be taken in by a fan which can be connected using external control unit.	<b>Weekly Timer</b> Differnt on-off times can be set for each day.	<b>Weekly + Setback Timer</b> Weekly + Setback timer can set temperature for two times spans and for each day of the week.	<b>Coil Dry</b> The indoor unit can be dried to prevent the growth of mold and bacteria.	<b>Washable Panel</b>
<b>Auto Restart</b> In the event of a temporary power failure, the air conditioner will automatically restart in the same operating mode as before, once the power supply is restored.	<b>Economy Mode</b> Limits the maximum operation current, and performs operation with the power consumption suppressed.	<b>Filter Sign</b> Indicates the filter cleaning period by lamp.			
<b>Auto-Changeover</b> The unit automatically switches between heating and cooling modes based on your temperature setting and the room temperature.	<b>Energy Saving Mode</b> This mode raises the set temperature slightly in the cooling mode and lowers the set temperature in the heating mode to economically control the operation of the unit.				
<b>V-PAM control models</b>					
<b>i-PAM control models</b>					

## Feature Summary

		Up/Down Swing Flaps	Double Swing Automatic	Automatic Air Flow Adjustment	Auto-Changeover	Auto Restart	Connectable Distributing Duct	Connectable Fresh Air Duct	Fresh Air Intake	Economy Mode	Energy Saving Mode	Sleep Timer	ON-OFF Timer	Program Timer	Weekly Timer	Weekly + Setback Timer	Filter Sign	Automatic Filter	UV Filter Cleaner	Plasma Air Cleaner	Long-life Ion Deodorization Filter	Apple-catechin Filter	Coil Dry	Washable Panel
WALL MOUNTED	AWYZ14LB/18LB/24LB	●	●	●	●	●	●	●	●	●	●	●	●	●	●	●	●	●	●	●	●	●	●	●
	ASYB09LD/12LD/18LD	●	●	●	●	●	●	●	●	●	●	●	●	●	●	●	●	●	●	●	●	●	●	●
	ASYB24LD	●	●	●	●	●	●	●	●	●	●	●	●	●	●	●	●	●	○	●	●	●	●	●
	ASYA07LG/09LG/12LG/14LG	●	●	●	●	●	●	●	●	●	●	●	●	●	●	●	●	●	○	●	●	●	●	●
	ASYA18LE/24LC/30LC	●	●	●	●	●	●	●	●	●	●	●	●	●	●	●	●	●	○	●	●	●	●	●
	ASY7UB/9UC/12UC	●	●	●	●	●	●	●	●	●	●	●	●	●	●	●	●	●	○	●	●	●	●	●
	ASY14UB	●	●	●	●	●	●	●	●	●	●	●	●	●	●	●	●	●	○	●	●	●	●	●
FLOOR	AGYF09LA/12LA/14LA	●	●	●	●	●	●	●	●	●	●	●	●	●	●	●	●	○	●	●	●	●	●	●
INVERTER MULTI	AOY18LMAM2	●	●	●	●	●	●	●	●	●	●	●	●	●	●	●	●	●	○	●	●	●	●	●
	AOY24LMAM2	●	●	●	●	●	●	●	●	●	●	●	●	●	●	●	●	●	○	●	●	●	●	●
	AOYA18LAT3	●	●	●	●	●	●	●	●	●	●	●	●	●	●	●	●	●	○	●	●	●	●	●
	AOYA24LAT3	●	●	●	●	●	●	●	●	●	●	●	●	●	●	●	●	●	○	●	●	●	●	●
	AOY30LMAW4	●	●	●	●	●	●	●	●	●	●	●	●	●	●	●	●	●	○	●	●	●	●	●
	ARYF09LA/12LA/14LA/18LA/22LA	●	●	●	●	●	●	●	●	●	●	○	●	○	●	●	●	●	○	●	●	●	●	●
COMPACT CASSETTE	AUYF(A)12LA/14LA/18LA/24LB	●	●	●	●	●	●	●	●	●	○	●	●	●	●	●	●	○	●	●	●	●	●	●
	AUY12UB/14UB/18UB	●	●	●	●	●	●	●	●	●	○	●	●	●	●	●	●	○	●	●	●	●	●	●
	AUYA30LB/36LB	●	●	●	●	●	●	●	●	●	○	●	○	●	●	●	●	○	●	●	●	●	●	●
	AUYA45LA	●	●	●	●	●	●	●	●	●	○	●	○	●	●	●	●	○	●	●	●	●	●	●
CASSETTE	AUY54LU	●	●	●	●	●	●	●	●	○	●	○	●	●	●	●	●	○	●	●	●	●	●	●
	AUY25UU/30UU/36UU/45UU/54UU	●	●	●	●	●	●	●	●	●	○	●	○	●	●	●	●	○	●	●	●	●	●	●
	FLOOR/CEILING UNIVERSAL	●	●	●	●	●	●	●	●	●	○	●	○	●	●	●	●	○	●	●	●	●	●	●
CEILING	ABYF18LA/24LA	●	●	●	●	●	●	●	●	●	○	●	○	●	●	●	●	○	●	●	●	●	●	●
	ABY14UB/18UB/24UB	●	●	●	●	●	●	●	●	●	○	●	○	●	●	●	●	○	●	●	●	●	●	●
DUCT	ABYA30LB/36LB/45LA	●	●	●	●	●	●	●	●	○	●	○	●	○	●	●	●	○	●	●	●	●	●	●
	ABY30UB/36UB/45UB/54UB	●	●	●	●	●	●	●	●	●	○	●	○	●	●	●	●	○	●	●	●	●	●	●
	ARYF12LA/14LA/18LA	●	●	●	●	●	●	●	●	○	○	○	○	○	○	○	○	○	○	○	○	○	○	○
	ARYA24LA	●	●	●	●	●	●	●	●	○	○	○	○	○	○	○	○	○	○	○	○	○	○	○
	ARYA30LB/36LB/45LA	●	●	●	●	●	●	●	●	○	○	○	○	○	○	○	○	○	○	○	○	○	○	○
	ARY45LH/54LU	●	●	●	●	●	●	●	●	○	○	○	○	○	○	○	○	○	○	○	○	○	○	○
	ARY7UU/9UU/12UU/14UU/18UU	●	●	●	●	●	●	●	●	○	○	○	○	○	○	○	○	○	○	○	○	○	○	○
	ARY25UU/30UU/36UU/45UU	●	●	●	●	●	●	●	●	○	○	○	○	○	○	○	○	○	○	○	○	○	○	○
ARY60UU	●	●	●	●	●	●	●	●	○	○	○	○	○	○	○	○	○	○	○	○	○	○	○	
ARY90TL	●	●	●	●	●	●	●	●	○	○	○	○	○	○	○	○	○	○	○	○	○	○	○	
MULTI	AOY19U	●	●	●	●	●	●	●	●	●	●	●	●	●	●	●	●	●	○	●	●	●	●	●
	AOY20USS	●	●	●	●	●	●	●	●	●	●	●	●	●	●	●	●	●	○	●	●	●	●	●
	AOY20USU	●	●	●	●	●	●	●	●	○	○	○	○	○	○	○	○	○	○	○	○	○	○	○
	AOY24USS	●	●	●	●	●	●	●	●	○	○	○	○	○	○	○	○	○	○	○	○	○	○	○
	AOY24USU	●	●	●	●	●	●	●	●	○	○	○	○	○	○	○	○	○	○	○	○	○	○	○
	AOY24UUU	●	●	●	●	●	●	●	●	○	○	○	○	○	○	○	○	○	○	○	○	○	○	○

○:Optional Feature

## Optional parts

### Flange (Round)

Model : UTD-RF204



### Flange (Square)

Model : UTD-SF045T



### Long-Life Filter

Model : UTD-LF25NA



### Long-Life Filter

Model : UTD-LF60KA



### Remote Sensor Unit

Model : UTD-RS100

New amenity space can be offered by installing the Remote sensor in the remote controller.



### External Control Set

Model : UTD-ECS5A

Use to connect with various peripheral devices and air conditioner PC board.

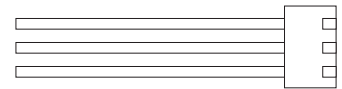

### Simple Remote Controller

Model : UTB-YPB



### Wired Remote Controller

Model : UTB-YUD

Model : UTH-3TA16



### Wireless Remote Controller

Model : UTB-YNA



### Drain Pump Unit

Model : UTZ-PX1BBA

Model : UTZ-PX1NBA



### Drain Pump Unit

Model : UTR-DPB24T



### IR Receiver Unit

Model : UTY-LRHY1

Model : UTY-LRJY1



### IR Receiver Kit

Model : UTY-LRHYA1



### Wide Panel

Model : UTG-AGYA-W

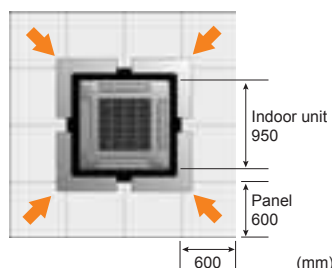

### Additional Grille

Model : UTG-AGDA-W

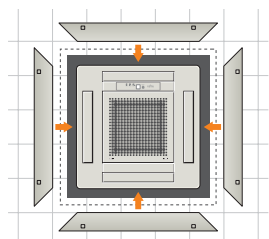



## Notice for specifications

I.U.=Indoor Unit    O.U.=Outdoor Unit    Qu=Quiet    \* =Not decided yet

- Specifications and design subject to change without notice for further improvement.  
Please check with your dealer.
- Cooling/Heating capacities are based on the following conditions.

Cooling	Indoor temp. : 27°C DB/19°C WB Outdoor temp. : 35°C DB/24°C WB	Heating	Indoor temp. : 20°C DB/15°C WB Outdoor temp. : 7°C DB/6°C WB
---------	---	---------	---



ISO 9001 Certified number:09 100 89394  
Fujitsu General (Thailand) Co., Ltd.

ISO 14001 Certified number:09 104 9245



ISO 9001 Certified number:09 100 79269  
Fujitsu General (Shanghai) Co., Ltd.



ISO 14001 Certified number:104692

Distributed by :